

FEATURES

Analog I/O

- Multi-Channel, 12-bit, 1MSPS ADC
 - Up to 16 ADC channels*
- Fully differential and single-ended modes
- 0 to V_{REF} Analog Input Range
- 12-bit Voltage Output DACs
 - Up to 4 DAC outputs available*
- On-Chip 20ppm/°C Voltage Reference
- On-Chip Temperature Sensor ($\pm 3^\circ\text{C}$)
- Uncommitted Voltage Comparator

Microcontroller

- ARM7TDMI Core, 16/32-bit RISC architecture
- JTAG Port supports code download and debug

Clocking options:

- Trimmed On-Chip Oscillator ($\pm 3\%$)
- External Watch crystal
- External clock source

45MHz PLL with Programmable Divider

Memory

- 62k Bytes Flash/EE Memory, 8k Bytes SRAM
- In-Circuit Download, JTAG based Debug
- Software triggered in-circuit re-programmability

On-Chip Peripherals

- UART, 2 I²C and SPI Serial I/O
- Up to 40-Pin GPIO Port*

2 X General Purpose Timers

Wake-up and Watchdog Timers

Power Supply Monitor

Three-phase 16-bit PWM generator*

PLA – Programmable Logic (Array)

Power

Specified for 3V operation

Active Mode: 3mA (@1MHz)

50mA (@45MHz)

Packages and Temperature Range

From 40 lead 6x6mm LFCSP to 80 pin LQFP*

Fully specified for -40°C to 85°C operation

Tools

Low-Cost QuickStart Development System

Full Third-Party Support

* Package, PWM, GPIO availability and number of Analog I/O depend on part model. See page 9.

APPLICATIONS

Industrial Control and Automation Systems

Smart Sensors, Precision Instrumentation

Base Station Systems, Optical Networking

(See general description on page 11)

FUNCTIONAL BLOCK DIAGRAM

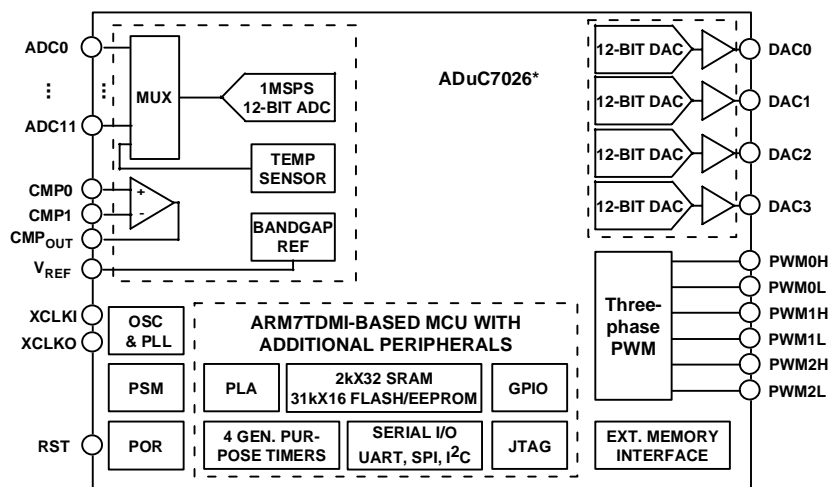

Figure 1

Rev. PrA

Information furnished by Analog Devices is believed to be accurate and reliable. However, no responsibility is assumed by Analog Devices for its use, nor for any infringements of patents or other rights of third parties that may result from its use. Specifications subject to change without notice. No license is granted by implication or otherwise under any patent or patent rights of Analog Devices. Trademarks and registered trademarks are the property of their respective companies.

TABLE OF CONTENTS

ADuC702x—Specifications	3	Reset and Remap	35
Terminology	6	Other analog peripherals	36
Absolute Maximum Ratings.....	7	DAC.....	36
Ordering Guide.....	9	Power Supply Monitor	38
Pin function descriptions	10	Comparator	38
General Description	19	Oscillator and PLL - Power control	39
Overview of the ARM7TDMI core	19	Digital peripherals	41
Memory organisation.....	20	Three-phase PWM.....	41
ADC circuit information	25	General Purpose I/O.....	48
General Overview.....	25	Serial Port Mux.....	50
ADC Transfer Function.....	25	Programmable Logic Array (PLA).....	60
Typical Operation.....	26	Processor reference peripherals.....	63
Converter operation.....	28	Interrupt System.....	63
Driving the analog inputs.....	29	Timers.....	65
ADC Calibration	29	ADuC702x Hardware Design considerations	73
Temperature Sensor	29	Power supplies	73
Bandgap Reference.....	29	Grounding and Board Layout Recommendations.....	73
Nonvolatile Flash/EE Memory	31	Clock Oscillator	74
Flash/EE memory overview	31	Power-on reset operation	74
Flash/EE Memory and the ADuC702x.....	31	Typical sysem configuration	75
Flash/EE memory security	31	Development Tools	76
Flash/EE Control Interface.....	32	In-Circuit Serial Downloader.....	76
Execution time from SRAM and FLASH/EE	33	Outline Dimensions	77

ADUC702X—SPECIFICATIONS ¹**Table 1. (AV_{DD} = IOV_{DD} = 2.7 V to 3.6 V, V_{REF} = 2.5 V Internal Reference, f_{CORE} = 45MHz, All specifications T_A = T_{MAX} to T_{MIN}, unless otherwise noted.)**

Parameter	ADuC702x	Unit	Test Conditions/Comments
ADC CHANNEL SPECIFICATIONS			
ADC Powerup Time	500	μs	
DC Accuracy ^{2,3}			f _{SAMPLE} = 1MSPS
Resolution	12	Bits	
Integral Nonlinearity	±1.5	LSB max	2.5V internal reference
	±0.5	LSB typ	2.5V internal reference
Integral Nonlinearity ⁴	±2.0	LSB max	1.0V external reference
Differential Nonlinearity	+1/-0.9	LSB max	2.5V internal reference
	±0.5	LSB typ	2.5V internal reference
Differential Nonlinearity ⁴	+1/-0.9	LSB max	1.0V external reference
DC Code Distribution	1	LSB typ	ADC input is a dc voltage
CALIBRATED ENDPOINT ERRORS ⁵			
Offset Error	±5	LSB max	
Offset Error Match	±1	LSB typ	
Gain Error	±5	LSB max	
Gain Error Match	±1	LSB typ	
DYNAMIC PERFORMANCE			
Signal-to-Noise Ratio (SNR) ⁶	71	dB typ	Fin = 10kHz Sine Wave, f _{SAMPLE} = 1MSPS
Total Harmonic Distortion (THD)	-78	dB typ	
Peak Harmonic or Spurious Noise	-78	dB typ	
Channel-to-Channel Crosstalk ⁷	-80	dB typ	
ANALOG INPUT			
Input Voltage Ranges			
Differential mode	V _{CM} ⁸ ± V _{REF} /2	Volts	
Single-ended mode	0 to V _{REF}	Volts	
Leakage Current	±5	μA max	
Input Capacitance	20	pF typ	During ADC Acquisition
ON-CHIP VOLTAGE REFERENCE			
Output Voltage	2.5	V	0.47μF from V _{REF} to AGND
Accuracy	±10	mV max	Measured at T _A = 25°C
Reference Temperature Coefficient	±10	ppm/°C typ	
Power Supply Rejection Ratio	80	dB typ	
Output Impedance	10	Ω typ	
Internal V _{REF} Power-On Time	1	ms typ	
EXTERNAL REFERENCE INPUT⁹			
Input Voltage Range	0.625 AV _{DD}	V min V max	
Input Impedance	TBD	KΩ typ	
DAC CHANNEL SPECIFICATIONS			
R _L = 5kΩ, C _L = 100pF			
DC ACCURACY			
Resolution	12	Bits	
Relative Accuracy	±2	LSB typ	
Differential Nonlinearity	±1	LSB max	Guaranteed Monotonic
Offset Error	±2	mV max	DAC output unbuffered
	±5	mV max	DAC output buffered
Gain Error	±0.5	% max	
Gain Error Mismatch	TBD	% typ	% of fullscale on DAC0

Parameter	ADuC702x	Unit	Test Conditions/Comments
ANALOG OUTPUTS			
Output Voltage Range_0	0 to DACREF	V typ	DACREF range: DACGND to DACV _{DD}
Output Voltage Range_1	0 to 2.5V	V typ	
Output Voltage Range_2	0 to DACV _{DD}	V typ	
Output Impedance	10	Ω typ	
DAC AC CHARACTERISTICS			
Voltage Output Settling Time	10	μs typ	DAC Output buffered
Voltage Output Settling Time	15	μs typ	DAC Output unbuffered
Digital to Analog Glitch Energy	TBD	nV-sec typ	1 LSB change at major carry
COMPARATOR			
Input Offset Voltage	±10	mV	Hysteresis can be turned on or off via the CMPHYST bit in the CMPCON register Response time may be modified via the CMPRES bits in the CMPCON register
Input Bias Current	5	nA typ	
Input Voltage Range	AGND to AV _{DD} -1.2	Vmin/Vmax	
Input Capacitance	7	pF typ	
Hysteresis	5	mV min	
	10	mv max	
Response Time	1	μs min	
	10	μs max	
TEMPERATURE SENSOR			
Voltage Output at 25°C	TBD	mV typ	
Voltage TC	-2.0	mV/°C typ	
Accuracy	±3	°C typ	
POWER SUPPLY MONITOR (PSM)			
IOV _{DD} Trip Point Selection	2.79 3.07	V V	Two selectable Trip Points
Power Supply Trip Point Accuracy	±2.5	% max	Of the selected nominal Trip Point Voltage
Watchdog Timer (WDT)⁴			
Timeout Period	0 TBD	ms min ms max	
Flash/EE MEMORY			
Endurance ¹⁰	10,000	Cycles min	T _J = 55°C
Data Retention ¹¹	30	Years min	
Digital Inputs			All digital inputs including XTAL1 and XTAL2
Input Leakage Current	±10 ±1	μA max μA typ	
Input Capacitance	10	pF typ	
Logic Inputs⁴			All Logic inputs including XTAL1 and XTAL2
V _{INL} , Input Low Voltage	0.4	V max	
V _{INH} , Input High Voltage	2.0	V min	
Logic Outputs			
V _{OH} , Output High Voltage	IOV _{DD} - 400mV	V min	I _{SOURCE} = 1.6mA
V _{OL} , Output Low Voltage ¹²	0.4	V max	I _{SINK} = 1.6mA
MCU CLOCK RATE	355.5 45.5	kHz min MHz max	8 programmable core clock selections within this range
STARTUP TIME			Core Clock = TBD MHz
At Power-On	TBD		
From Idle Mode	TBD		
From Power-Down Mode	TBD		
Programmable Logic Array (PLA)			
Propagation Delay	TBD	ns typ	From input pin to output pin

Parameter	ADuC702x	Unit	Test Conditions/Comments
POWER REQUIREMENTS ^{13, 14}			
Power Supply Voltage Range			
AV _{DD} – AGND and IOV _{DD} - IOGND	2.7 3.6	V min V max	
Power Supply Current Normal Mode	3mA 5 50 60	mA typ mA max mA typ mA max	1MHz clock 1MHz clock 45MHz clock 45MHz clock
Power Supply Current Idle Mode	1	mA max	
Power Supply Current Power Down Mode	30 100	µA typ µA max	External Crystal or Internal Osc ON External Crystal or Internal Osc ON

¹ Temperature Range -40° to +85°C

² All ADC Channel Specifications are guaranteed during normal MicroConverter core operation.

³ These specification apply to all ADC input channels.

⁴ These numbers are not production tested but are supported by design and/or characterization data on production release.

⁵ Based on external ADC system components, the user may need to execute a system calibration to remove external endpoint and achieve these specifications..

⁶ SNR calculation includes distortion and noise components.

⁷ Channel-to-channel crosstalk is measured on adjacent channels.

⁸ The input signal can be centered on any dc common-mode voltage (V_{CM}) as long as this value is within the ADC voltage input range specified.

⁹ When using an external reference input pin, the internal reference must be disabled by setting the Isb in the REFCON Memeory Mapped Register to 0.

¹⁰ Endurance is qualified to 50,000 cycles as per JEDEC Std. 22 method A117 and measured at -40°C, +25°C and +85°C. Typical endurance at 25°C is 70,000 cycles.

¹¹ Retention lifetime equivalent at junction temperature (Tj) = 55°C as per JEDEC Std. 22 method A117. Retention lifetime will derate with junction temperature.

¹² Test carried out with a maximum of 20 I/O set to a low output level.

¹³ Power supply current consumption is measured in normal, idle and power-down modes under the following conditions:

Normal Mode: TBD

Idle Mode: TBD

Power-Down: TBD

¹⁴ DV_{DD} power supply current increases typically by TBD mA during a Flash/EE memory program or erase cycle.

TERMINOLOGY

ADC Specifications

Integral Nonlinearity

This is the maximum deviation of any code from a straight line passing through the endpoints of the ADC transfer function. The endpoints of the transfer function are zero scale, a point 1/2 LSB below the first code transition and full scale, a point 1/2 LSB above the last code transition.

Differential Nonlinearity

This is the difference between the measured and the ideal 1 LSB change between any two adjacent codes in the ADC.

Offset Error

This is the deviation of the first code transition (0000 ... 000) to (0000 ... 001) from the ideal, i.e., +1/2 LSB.

Gain Error

This is the deviation of the last code transition from the ideal AIN voltage (Full Scale – 1.5 LSB) after the offset error has been adjusted out.

Signal to (Noise + Distortion) Ratio

This is the measured ratio of signal to (noise + distortion) at the output of the ADC. The signal is the rms amplitude of the

fundamental. Noise is the rms sum of all nonfundamental signals up to half the sampling frequency ($f_s/2$), excluding dc. The ratio is dependent upon the number of quantization levels in the digitisation process; the more levels, the smaller the quantization noise. The theoretical signal to (noise + distortion) ratio for an ideal N-bit converter with a sine wave input is given by:

$$\text{Signal to (Noise + Distortion)} = (6.02N + 1.76) \text{ dB}$$

Thus for a 12-bit converter, this is 74 dB.

Total Harmonic Distortion

Total Harmonic Distortion is the ratio of the rms sum of the harmonics to the fundamental.

DAC SPECIFICATIONS

Relative Accuracy

Relative accuracy or endpoint linearity is a measure of the maximum deviation from a straight line passing through the endpoints of the DAC transfer function. It is measured after adjusting for zero error and full-scale error.

Voltage Output Settling Time

This is the amount of time it takes for the output to settle to within a 1 LSB level for a full-scale input change..

ABSOLUTE MAXIMUM RATINGS

Table 2. Absolute Maximum Ratings (T_A = 25°C unless otherwise noted)

Parameter	Rating
AV _{DD} to DV _{DD}	TBD
AGND to DGND	TBD
DV _{DD} to DGND, AV _{DD} to AGND	TBD
Digital Input Voltage to DGND	TBD
Digital Output Voltage to DGND	TBD
VREF to AGND	TBD
Analog Inputs to AGND	TBD
Operating Temperature Range Industrial ADuC702x	-40°C to +85°C
Storage Temperature Range	TBD
Junction Temperature	TBD
θ _{JA} Thermal Impedance (CSP)	TBD
θ _{JA} Thermal Impedance (LQFP)	TBD
Lead Temperature, Soldering	
Vapor Phase (60 sec)	TBD
Infrared (15 sec)	TBD

Stresses above those listed under Absolute Maximum Ratings may cause permanent damage to the device. This is a stress rating only; functional operation of the device at these or any other conditions above those listed in the operational sections of this specification is not implied. Exposure to absolute maximum rating conditions for extended periods may affect device reliability.

ESD Caution

ESD (electrostatic discharge) sensitive device. Electrostatic charges as high as 4000 V readily accumulate on the human body and test equipment and can discharge without detection. Although this product features proprietary ESD protection circuitry, permanent damage may occur on devices subjected to high-energy electrostatic discharges. Therefore, proper ESD precautions are recommended to avoid performance degradation or loss of functionality.



PIN CONFIGURATION

40-Lead CSP

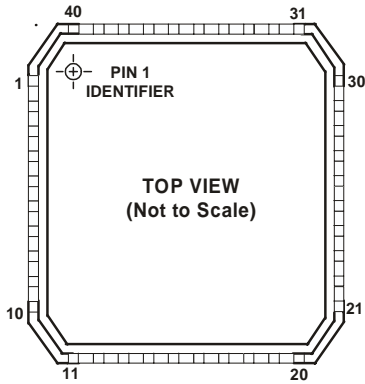

64-Lead LQFP

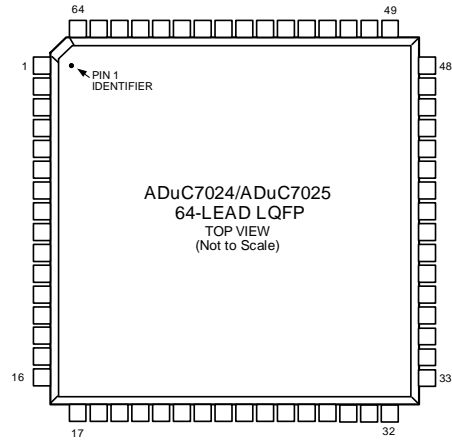

64-Lead CSP



80-Lead LQFP



ORDERING GUIDE

Model	ADC Channels	DAC Channels	FLASH / RAM	PWM	Ext Memory	GPIO	Temp Range	Package Description	Package Option
ADuC7020BCP62	5	4	62kB/8kB			14	-40°C to +85°C	40-Lead Chip Scale Package	CP-40
ADuC7021BCP62	8	2	62kB/8kB			13	-40°C to +85°C	40-Lead Chip Scale Package	CP-40
ADuC7021BCP32	8	2	32kB/4kB			13	-40°C to +85°C	40-Lead Chip Scale Package	CP-40
ADuC7021ACP32	8 (10 Bit NMC)	2	32kB/4kB			13	-40°C to +85°C	40-Lead Chip Scale Package	CP-40
ADuC7022BCP62	10		62kB/8kB			13	-40°C to +85°C	40-Lead Chip Scale Package	CP-40
ADuC7022BCP32	10		32kB/4kB			13	-40°C to +85°C	40-Lead Chip Scale Package	CP-40
ADuC7022ACP32	10 (10 Bit NMC)		62kB/8kB			13	-40°C to +85°C	40-Lead Chip Scale Package	CP-40
ADuC7024BCP62	10	2	62kB/8kB	Yes		30	-40°C to +85°C	64-Lead Chip Scale Package	CP-64-1
ADuC7024BST62	10	2	62kB/8kB	Yes		30	-40°C to +85°C	64 Lead Plastic Quad Flatpack	ST-64
ADuC7025BCP62	12		62kB/8kB	Yes		30	-40°C to +85°C	64-Lead Chip Scale Package	CP-64-1
ADuC7025BCP32	12		32kB/4kB	Yes		30	-40°C to +85°C	64-Lead Chip Scale Package	CP-64-1
ADuC7026BST62	12	4	62kB/8kB	Yes	Yes	40	-40°C to +85°C	80 Lead Plastic Quad Flatpack	ST-80
ADuC7027BST62	16		62kB/8kB	Yes	Yes	40	-40°C to +85°C	80 Lead Plastic Quad Flatpack	ST-80
ADuC7027AST62	16 (10 Bit NMC)		62kB/8kB	Yes	Yes	40	-40°C to +85°C	80 Lead Plastic Quad Flatpack	ST-80
EVAL-ADuC7020QS								Development System	
EVAL-ADuC7024QS								Development System	
EVAL-ADuC7026QS								Development System	

Contact the factory for chip availability.

PIN FUNCTION DESCRIPTIONS – ADUC7020/ADUC7021/ADUC7022

Table 3. Pin Function Descriptions

Pin# ADuC702X			Mnemonic	Type*	Function
7020	7021	7022			
38	37	36	ADC0	I	Single-ended or differential Analog input 0
39	38	37	ADC1	I	Single-ended or differential Analog input 1
40	39	38	ADC2/CMP0	I	Single-ended or differential Analog input 2 / Comparator Positive Input
1	40	39	ADC3/CMP1	I	Single-ended or differential Analog input 3 / Comparator Negative Input
2	1	40	ADC4	I	Single-ended or differential Analog input 4
-	2	1	ADC5	I	Single-ended or differential Analog input 5
-	3	2	ADC6	I	Single-ended or differential Analog input 6
-	4	3	ADC7	I	Single-ended or differential Analog input 7
-	-	4	ADC8	I	Single-ended or differential Analog input 8
-	-	5	ADC9	I	Single-ended or differential Analog input 9
3	5	6	GND _{REF}	S	Ground voltage reference for the ADC. For optimal performance the analog power supply should be separated from IOGND and DGND
4	6	-	DAC0/ADC12	I/O	DAC0 Voltage Output / Single-ended or differential Analog input 12
5	7	-	DAC1/ADC13	I/O	DAC1 Voltage Output / Single-ended or differential Analog input 13
6	-	-	DAC2/ADC14	I/O	DAC2 Voltage Output / Single-ended or differential Analog input 14
7	-	-	DAC3/ADC15	I/O	DAC3 Voltage Output / Single-ended or differential Analog input 15
8	8	7	TMS	I	JTAG Test Port Input - Test Mode Select. Debug and download access
9	9	8	TDI	I	JTAG Test Port Input – Test Data In. Debug and download access
10	10	9	BM/P0.0/CMP _{OUT} /PLAI[7]	I/O	Multifunction I/O pin: Boot Mode. The ADuC702X will enter UART serial download mode if BM is low at reset and will execute code if BM is pulled high at reset through a 1kOhm resistor/ General Purpose Input-Output Port 0.0 / Voltage Comparator Output/ Programmable Logic Array Input Element 7
11	11	10	P0.6/T1/MRST/PLAO[3]	O	Multifunction pin: driven low after reset General Purpose Output Port 0.6 / Timer 1 Input / Power on reset output / Programmable Logic Array Output Element 3
12	12	11	TCK/XCLK	I	JTAG Test Port Input - Test Clock. Debug and download access / Input to the internal clock generator circuits
13	13	12	TDO	O	JTAG Test Port Output - Test Data Out. Debug and download access
14	14	13	IOGND	S	Ground for GPIO. Typically connected to DGND
15	15	14	IOV _{DD}	S	3.3V Supply for GPIO and input of the on-chip voltage regulator.
16	16	15	LV _{DD}	S	2.5V. Output of the on-chip voltage regulator. Must be connected to a 0.47μF capacitor to DGND
17	17	16	DGND	S	Ground for core logic.
18	18	17	TRST	I	JTAG Test Port Output - Test Reset. Debug and download access
19	19	18	RST	I	Reset Input. (active low)
20	20	19	IRQ0/P0.4/CONV _{ST} _{ART} /PLAO[1]	I/O	Multifunction I/O pin: External Interrupt Request 0, active high / General Purpose Input-Output Port 0.4 / Start conversion input signal for ADC / Programmable Logic Array Output Element 1
21	21	20	IRQ1/P0.5/ADC _{BUSY} /PLAO[2]	I/O	Multifunction I/O pin: External Interrupt Request 1, active high / General Purpose Input-Output Port 0.5 / ADC _{BUSY} signal / Programmable Logic Array Output Element 2
22	22	21	P2.0/SPM9/PLAO[5]/CONV _{START}	I/O	Serial Port Multiplexed: General Purpose Input-Output Port 2.0 / UART / Programmable Logic Array Output Element 5/ Start conversion input signal for ADC
23	23	22	P0.7/ECLK/SPM8/PLAO[4]	I/O	Serial Port Multiplexed: General Purpose Input-Output Port 0.7 / Output for External Clock signal / UART / Programmable Logic Array Output Element 4

Pin# ADuC702X			Mnemonic	Type*	Function
7020	7021	7022			
24	24	23	XCLKO	O	Output to the crystal oscillator inverter
25	24	24	XCLKI	I	Input to the crystal oscillator inverter and input to the internal clock generator circuits
26	26	25	P1.7/SPM7/PLAO[0]	I/O	Serial Port Multiplexed: General Purpose Input-Output Port 1.7 / UART / SPI / Programmable Logic Array Output Element 0
27	27	26	P1.6/SPM6/PLAI[6]	I/O	Serial Port Multiplexed: General Purpose Input-Output Port 1.6 / UART / SPI / Programmable Logic Array Input Element 6
28	28	27	P1.5/SPM5/PLAI[5]	I/O	Serial Port Multiplexed: General Purpose Input-Output Port 1.5 / UART / SPI / Programmable Logic Array Input Element 5
29	29	28	P1.4/SPM4/PLAI[4]	I/O	Serial Port Multiplexed: General Purpose Input-Output Port 1.4 / UART / SPI / Programmable Logic Array Input Element 4
30	30	29	P1.3/SPM3/PLAI[3]	I/O	Serial Port Multiplexed: General Purpose Input-Output Port 1.3 / UART / I ² C1 / Programmable Logic Array Input Element 3
31	31	30	P1.2/SPM2/PLAI[2]	I/O	Serial Port Multiplexed: General Purpose Input-Output Port 1.2 / UART / I ² C1 / Programmable Logic Array Input Element 2
32	32	31	P1.1/SPM1/PLAI[1]	I/O	Serial Port Multiplexed: General Purpose Input-Output Port 1.1 / UART / I ² C0 / Programmable Logic Array Input Element 1
33	33	32	P1.0/T1/SPM0/PLAI[0]	I/O	Serial Port Multiplexed: General Purpose Input-Output Port 1.0/ Timer 1 Input / UART / I ² C0 / Programmable Logic Array Input Element 0
34	-	-	P4.2/PLAO[10]	I/O	General Purpose Input-Output Port 4.2 / Programmable Logic Array Output Element 10
35	34	33	V _{REF}	I/O	2.5V internal Voltage Reference. Must be connected to a 0.47uF capacitor when using the internal reference.
36	35	34	AGND	S	Analog Ground. Ground reference point for the analog circuitry
37	36	35	AV _{DD}	S	3.3V Analog Power

* I = Input, O = Output, S = Supply.
 - No pin assigned.

PIN FUNCTION DESCRIPTIONS – ADUC7024/ADUC7025

Table 4. Pin Function Descriptions

Pin#	Mnemonic	Type*	Function
1	ADC4	I	Single-ended or differential Analog input 4
2	ADC5	I	Single-ended or differential Analog input 5
3	ADC6	I	Single-ended or differential Analog input 6
4	ADC7	I	Single-ended or differential Analog input 7
5	ADC8	I	Single-ended or differential Analog input 8
6	ADC9	I	Single-ended or differential Analog input 9
7	GND _{REF}	S	Ground voltage reference for the ADC. For optimal performance the analog power supply should be separated from IOGND and DGND
8	ADCNEG	I	Bias point or Negative Analog Input of the ADC in pseudo differential mode. Must be connected to the ground of the signal to convert. This bias point must be between 0V and 1V
9	DAC0**/ADC12	I/O	DAC0 Voltage Output / Single-ended or differential Analog input 12
10	DAC1**/ADC13	I/O	DAC1 Voltage Output / Single-ended or differential Analog input 13
11	TMS	I	JTAG Test Port Input - Test Mode Select. Debug and download access
12	TDI	I	JTAG Test Port Input – Test Data In. Debug and download access
13	P4.6/PLAO[14]	I/O	General Purpose Input-Output Port 4.6/ Programmable Logic Array Output Element 14
14	P4.7/PLAO[15]	I/O	General Purpose Input-Output Port 4.7/ Programmable Logic Array Output Element 15
15	BM/P0.0/CMP _{OUT} /PLAI[7]	I/O	Multifunction I/O pin: Boot Mode. The ADuC7024/ADuC7025 will enter UART serial download mode if BM is low at reset and will execute code if BM is pulled high at reset through a 1kOhm resistor/ General Purpose Input-Output Port 0.0 / Voltage Comparator Output/ Programmable Logic Array Input Element 7
16	P0.6/T1/MRST/PLAO[3]	O	Multifunction pin: driven low after reset General Purpose Output Port 0.6 / Timer 1 Input / Power on reset output / Programmable Logic Array Output Element 3
17	TCK	I	JTAG Test Port Input - Test Clock. Debug and download access
18	TDO	O	JTAG Test Port Output - Test Data Out. Debug and download access
19	IOGND	S	Ground for GPIO. Typically connected to DGND
20	IOV _{DD}	S	3.3V Supply for GPIO and input of the on-chip voltage regulator.
21	LV _{DD}	S	2.5V. Output of the on-chip voltage regulator. Must be connected to a 0.47μF capacitor to DGND
22	DGND	S	Ground for core logic.
23	P3.0/PWM0 _H /PLAI[8]	I/O	General Purpose Input-Output Port 3.0/ PWM phase 0 high side output / Programmable Logic Array Input Element 8
24	P3.1/PWM0 _L /PLAI[9]	I/O	General Purpose Input-Output Port 3.1/ PWM phase 0 low side output / Programmable Logic Array Input Element 9
25	P3.2/PWM1 _H /PLAI[10]	I/O	General Purpose Input-Output Port 3.2/ PWM phase 1 high side output / Programmable Logic Array Input Element 10
26	P3.3/PWM1 _L /PLAI[11]	I/O	General Purpose Input-Output Port 3.3/ PWM phase 1 low side output / Programmable Logic Array Input Element 11
27	P0.3/TRST/ADC _{BUSY}	I/O	General Purpose Input-Output Port 0.3 / JTAG Test Port Input – Test Reset. Debug and download access / ADC _{BUSY} signal output
28	RST	I	Reset Input. (active low)
29	P3.4/PWM2 _H /PLAI[12]	I/O	General Purpose Input-Output Port 3.4 / PWM phase 2 high side output / Programmable Logic Array Input 12
30	P3.5/PWM2 _L /PLAI[13]	I/O	General Purpose Input-Output Port 3.5 / PWM phase 2 low side output / Programmable Logic Array Input Element 13

Pin#	Mnemonic	Type*	Function
31	IRQ0/P0.4/CONV _{START} /PLAO[1]	I/O	Multifunction I/O pin: External Interrupt Request 0, active high / General Purpose Input-Output Port 0.4 / Start conversion input signal for ADC / Programmable Logic Array Output Element 1
32	IRQ1/P0.5/ADC _{BUSY} /PLAO[2]	I/O	Multifunction I/O pin: External Interrupt Request 1, active high / General Purpose Input-Output Port 0.5 / ADC _{BUSY} signal / Programmable Logic Array Output Element 2
33	P2.0/PWM _{TRIP} /SPM9/PLAO[5]/CONV _{START}	I/O	Serial Port Multiplexed: General Purpose Input-Output Port 2.0 / PWM safety cut off / UART / Programmable Logic Array Output Element 5/ Start conversion input signal for ADC
34	P0.7/ECLK/SPM8/PLAO[4]	I/O	Serial Port Multiplexed: General Purpose Input-Output Port 0.7 / Output for External Clock signal / UART / Programmable Logic Array Output Element 4
35	XCLKO	O	Output to the crystal oscillator inverter
36	XCLKI	I	Input to the crystal oscillator inverter and input to the internal clock generator circuits
37	P3.6/PWM _{TRIP} /PLAI[14]	I/O	General Purpose Input-Output Port 3.6/ PWM safety cut off / Programmable Logic Array Input Element 14
38	P3.7/PWMSYNC/PLAI[15]	I/O	General Purpose Input-Output Port 3.7/ PWM synchronisation input output /Programmable Logic Array Input Element 15
39	P1.7/SPM7/PLAO[0]	I/O	Serial Port Multiplexed: General Purpose Input-Output Port 1.7 / UART / SPI / Programmable Logic Array Output Element 0
40	P1.6/SPM6/PLAI[6]	I/O	Serial Port Multiplexed: General Purpose Input-Output Port 1.6 / UART / SPI / Programmable Logic Array Input Element 6
41	I0GND	S	Ground for GPIO. Typically connected to DGND
42	I0V _{DD}	S	3.3V Supply for GPIO and input of the on-chip voltage regulator.
43	P4.0/PLAO[8]	I/O	General Purpose Input-Output Port 4.0 / Programmable Logic Array Output Element 8
44	P4.1/PLAO[9]	I/O	General Purpose Input-Output Port 4.1 / Programmable Logic Array Output Element 9
45	P1.5/SPM5/PLAI[5]	I/O	Serial Port Multiplexed: General Purpose Input-Output Port 1.5 / UART / SPI / Programmable Logic Array Input Element 5
46	P1.4/SPM4/PLAI[4]	I/O	Serial Port Multiplexed: General Purpose Input-Output Port 1.4 / UART / SPI / Programmable Logic Array Input Element 4
47	P1.3/SPM3/PLAI[3]	I/O	Serial Port Multiplexed: General Purpose Input-Output Port 1.3/ UART / I ² C1 /Programmable Logic Array Input Element 3
48	P1.2/SPM2/PLAI[2]	I/O	Serial Port Multiplexed: General Purpose Input-Output Port 1.2 / UART / I ² C1 /Programmable Logic Array Input Element 2
49	P1.1/SPM1/PLAI[1]	I/O	Serial Port Multiplexed: General Purpose Input-Output Port 1.1 / UART / I ² C0 / Programmable Logic Array Input Element 1
50	P1.0/T1/SPM0/PLAI[0]	I/O	Serial Port Multiplexed: General Purpose Input-Output Port 1.0/ Timer 1 Input / UART / I ² C0 / Programmable Logic Array Input Element 0
51	P4.2/PLAO[10]	I/O	General Purpose Input-Output Port 4.2 / Programmable Logic Array Output Element 10

Pin#	Mnemonic	Type*	Function
52	P4.3/PLAO[11]	I/O	General Purpose Input-Output Port 4.3 / Programmable Logic Array Output Element 11
53	P4.4/PLAO[12]	I/O	General Purpose Input-Output Port 4.4 / Programmable Logic Array Output Element 12
54	P4.5/PLAO[13]	I/O	General Purpose Input-Output Port 4.5 / Programmable Logic Array Output Element 13
55	V _{REF}	I/O	2.5V internal Voltage Reference. Must be connected to a 0.47uF capacitor when using the internal reference.
56	DAC _{REF}	I	External Voltage Reference for the DACs. Range: DACGND to DACV _{DD}
57	DACGND	S	Ground for the DAC. Typically connected to AGND
58	AGND	S	Analog Ground. Ground reference point for the analog circuitry
59	AV _{DD}	S	3.3V Analog Power
60	DACV _{DD}	S	3.3V Power Supply for the DACs. Typically connected to AV _{DD}
61	ADC0	I	Single-ended or differential Analog input 0
62	ADC1	I	Single-ended or differential Analog input 1
63	ADC2/CMP0	I	Single-ended or differential Analog input 2/ Comparator positive input
64	ADC3/CMP1	I	Single-ended or differential Analog input 3/ Comparator negative input

* I = Input, O = Output, S = Supply.

** DAC outputs not present on ADuC7025

PIN FUNCTION DESCRIPTIONS – ADUC7026/ADUC7027

Table 5. Pin Function Descriptions

Pin#	Mnemonic	Type*	Function
1	ADC4	I	Single-ended or differential Analog input 4
2	ADC5	I	Single-ended or differential Analog input 5
3	ADC6	I	Single-ended or differential Analog input 6
4	ADC7	I	Single-ended or differential Analog input 7
5	ADC8	I	Single-ended or differential Analog input 8
6	ADC9	I	Single-ended or differential Analog input 9
7	ADC10	I	Single-ended or differential Analog input 10
8	GND _{REF}	S	Ground voltage reference for the ADC. For optimal performance the analog power supply should be separated from IOGND and DGND
9	ADCNEG	I	Bias point or Negative Analog Input of the ADC in pseudo differential mode. Must be connected to the ground of the signal to convert. This bias point must be between 0V and 1V
10	DAC0/ADC12	I/O	DAC0 Voltage Output / Single-ended or differential Analog input 12
11	DAC1/ADC13	I/O	DAC1 Voltage Output / Single-ended or differential Analog input 13
12	DAC1/ADC14	I/O	DAC2 Voltage Output / Single-ended or differential Analog input 14
13	DAC1/ADC15	I/O	DAC3 Voltage Output / Single-ended or differential Analog input 15
14	TMS	I	JTAG Test Port Input - Test Mode Select. Debug and download access
15	TDI	I	JTAG Test Port Input – Test Data In. Debug and download access
16	P0.1/ $\overline{\text{BLE}}$	I/O	General Purpose Input-Output Port 0.1
17	P2.3/AE		
18	P4.6/AD14/PLAO[14]	I/O	General Purpose Input-Output Port 4.6/ External Memory Interface/Programmable Logic Array Output Element 14
19	P4.7/AD15/PLAO[15]	I/O	General Purpose Input-Output Port 4.7/ External Memory Interface / Programmable Logic Array Output Element 15
20	BM/P0.0/CMP _{OUT} /PLAI[7]	I/O	Multifunction I/O pin: Boot Mode. The ADuC7026 will enter UART serial download mode if BM is low at reset and will execute code if BM is pulled high at reset through a 1kOhm resistor/ General Purpose Input-Output Port 0.0 / Voltage Comparator Output/ Programmable Logic Array Input Element 7
21	P0.6/T1/MRST/PLAO[3]/AE	O	Multifunction pin: driven low after reset General Purpose Output Port 0.6 / Timer 1 Input / Power on reset output / Programmable Logic Array Output Element 3
22	TCK	I	JTAG Test Port Input - Test Clock. Debug and download access
23	TDO	O	JTAG Test Port Output - Test Data Out. Debug and download access
24	P0.2/ $\overline{\text{BHE}}$	I/O	General Purpose Input-Output Port 0.2
25	IOGND	S	Ground for GPIO. Typically connected to DGND
26	IOV _{DD}	S	3.3V Supply for GPIO and input of the on-chip voltage regulator.
27	LV _{DD}	S	2.5V. Output of the on-chip voltage regulator. Must be connected to a 0.47 μ F capacitor to DGND
28	DGND	S	Ground for core logic.
29	P3.0/AD0/PWM0 _H /PLAI[8]	I/O	General Purpose Input-Output Port 3.0 / External Memory Interface/ PWM phase 0 high side output / Programmable Logic Array Input Element 8
30	P3.1/AD1/PWM0 _L /PLAI[9]	I/O	General Purpose Input-Output Port 3.1 / External Memory Interface / PWM phase 0 low side output / Programmable Logic Array Input Element 9
31	P3.2/AD2/PWM1 _H /PLAI[10]	I/O	General Purpose Input-Output Port 3.2 / External Memory Interface / PWM phase 1 high side output / Programmable Logic Array Input Element 10
32	P3.3/AD3/PWM1 _L /PLAI[11]	I/O	General Purpose Input-Output Port 3.3 / External Memory Interface / PWM phase 1 low side output / Programmable Logic Array Input Element 11
33	P2.4/MS0	I/O	General Purpose Input-Output Port 2.4 / External Memory select 0

Pin#	Mnemonic	Type*	Function
34	P0.3/TRST/A16/ADC _{BUSY}	I/O	General Purpose Input-Output Port 0.3 / JTAG Test Port Input – Test Reset. Debug and download access / ADC _{BUSY} signal output
35	P2.5/MS1	I/O	General Purpose Input-Output Port 2.5 / External Memory select 1
36	P2.6/MS2	I/O	General Purpose Input-Output Port 2.6 / External Memory select 2
37	RST	I	Reset Input. (active low)
38	P3.4/AD4/PWM2 _H /PLAI[12]	I/O	General Purpose Input-Output Port 3.4 / External Memory Interface / PWM phase 2 high side output / Programmable Logic Array Input 12
39	P3.5/AD5/PWM2 _L /PLAI[13]	I/O	General Purpose Input-Output Port 3.5 / External Memory Interface / PWM phase 2 low side output / Programmable Logic Array Input Element 13
40	IRQ0/P0.4/CONV _{START} /PLAO[1]	I/O	Multifunction I/O pin: External Interrupt Request 0, active high / General Purpose Input-Output Port 0.4 / Start conversion input signal for ADC / Programmable Logic Array Output Element 1
41	IRQ1/P0.5/ADC _{BUSY} /PLAO[2]	I/O	Multifunction I/O pin: External Interrupt Request 1, active high / General Purpose Input-Output Port 0.5 / ADC _{BUSY} signal / Programmable Logic Array Output Element 2
42	P2.0/PWM _{TRIP} /SPM9/PLAO[5]/CONV _{START}	I/O	Serial Port Multiplexed: General Purpose Input-Output Port 2.0 / PWM safety cut off / UART / Programmable Logic Array Output Element 5/ Start conversion input signal for ADC
43	P0.7/ECLK/SPM8/PLAO[4]	I/O	Serial Port Multiplexed: General Purpose Input-Output Port 0.7 / Output for External Clock signal / UART / Programmable Logic Array Output Element 4
44	XCLKO	O	Output to the crystal oscillator inverter
45	XCLKI	I	Input to the crystal oscillator inverter and input to the internal clock generator circuits
46	P3.6/AD6/PWM _{TRIP} /PLAI[14]	I/O	General Purpose Input-Output Port 3.6 / External Memory Interface / PWM safety cut off / Programmable Logic Array Input Element 14
47	P3.7/AD7/ECLK/PLAI[15]	I/O	General Purpose Input-Output Port 3.7 / External Memory Interface / Output for External Clock signal / Programmable Logic Array Input Element 15
48	P2.7/MS3	I/O	General Purpose Input-Output Port 2.7 / External Memory select 3
49	P2.1/WS	I/O	General Purpose Input-Output Port 2.1 / External Memory Write Strobe
50	P2.2/RS	I/O	General Purpose Input-Output Port 2.2 / External Memory Read Strobe
51	P1.7/SPM7/PLAO[0]	I/O	Serial Port Multiplexed: General Purpose Input-Output Port 1.7 / UART / SPI / Programmable Logic Array Output Element 0
52	P1.6/SPM6/PLAI[6]	I/O	Serial Port Multiplexed: General Purpose Input-Output Port 1.6 / UART / SPI / Programmable Logic Array Input Element 6
53	IOGND	S	Ground for GPIO. Typically connected to DGND
54	IOV _{DD}	S	3.3V Supply for GPIO and input of the on-chip voltage regulator.
55	P4.0/AD8/PLAO[8]	I/O	General Purpose Input-Output Port 4.0 / External Memory Interface / Programmable Logic Array Output Element 8
56	P4.1/AD9/PLAO[9]	I/O	General Purpose Input-Output Port 4.1 / External Memory Interface / Programmable Logic Array Output Element 9
57	P1.5/SPM5/PLAI[5]	I/O	Serial Port Multiplexed: General Purpose Input-Output Port 1.5 / UART / SPI / Programmable Logic Array Input Element 5
58	P1.4/SPM4/PLAI[4]	I/O	Serial Port Multiplexed: General Purpose Input-Output Port 1.4 / UART / SPI / Programmable Logic Array Input Element 4
59	P1.3/SPM3/PLAI[3]	I/O	Serial Port Multiplexed:

Pin#	Mnemonic	Type*	Function
			General Purpose Input-Output Port 1.3/ UART / I ² C1 /Programmable Logic Array Input Element 3
60	P1.2/SPM2/PLAI[2]	I/O	Serial Port Multiplexed: General Purpose Input-Output Port 1.2 / UART / I ² C1 /Programmable Logic Array Input Element 2
61	P1.1/SPM1/PLAI[1]	I/O	Serial Port Multiplexed: General Purpose Input-Output Port 1.1 / UART / I ² C0 / Programmable Logic Array Input Element 1
62	P1.0/T1/SPM0/PLAI[0]	I/O	Serial Port Multiplexed: General Purpose Input-Output Port 1.0/ Timer 1 Input / UART / I ² C0 / Programmable Logic Array Input Element 0
63	P4.2/AD10/PLAO[10]	I/O	General Purpose Input-Output Port 4.2 / External Memory Interface / Programmable Logic Array Output Element 10
64	P4.3/AD11/PLAO[11]	I/O	General Purpose Input-Output Port 4.3 / External Memory Interface /Programmable Logic Array Output Element 11
65	P4.4/AD12/PLAO[12]	I/O	General Purpose Input-Output Port 4.4 / External Memory Interface /Programmable Logic Array Output Element 12
66	P4.5/AD13/PLAO[13]	I/O	General Purpose Input-Output Port 4.5 / External Memory Interface /Programmable Logic Array Output Element 13
67	REFGND	S	Ground for the reference. Typically connected to AGND
68	V _{REF}	I/O	2.5V internal Voltage Reference. Must be connected to a 0.47uF capacitor when using the internal reference.
69	DAC _{REF}	I	External Voltage Reference for the DACs. Range: DACGND to DACV _{DD}
70	DACGND	S	Ground for the DAC. Typically connected to AGND
71	AGND	S	Analog Ground. Ground reference point for the analog circuitry
72	AGND	S	Analog Ground. Ground reference point for the analog circuitry
73	AV _{DD}	S	3.3V Analog Power
74	AV _{DD}	S	3.3V Analog Power
75	DACV _{DD}	S	3.3V Power Supply for the DACs. Typically connected to AV _{DD}
76	ADC11	I	Single-ended or differential Analog input 11
77	ADC0	I	Single-ended or differential Analog input 0
78	ADC1	I	Single-ended or differential Analog input 1
79	ADC2/CMP0	I	Single-ended or differential Analog input 2/ Comparator positive input
80	ADC3/CMP1	I	Single-ended or differential Analog input 3/ Comparator negative input

* I = Input, O = Output, S = Supply.

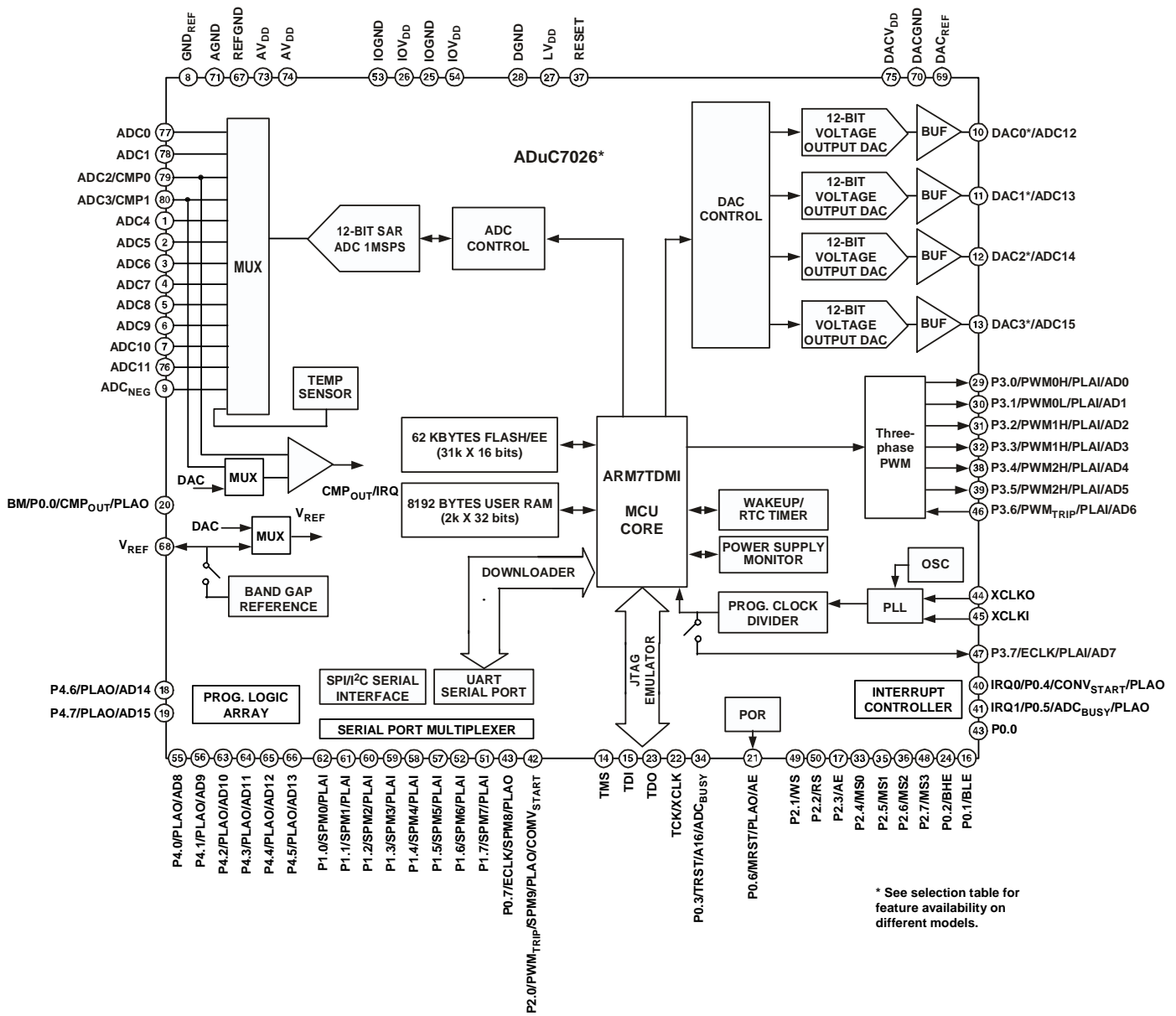

* See selection table for feature availability on different models.

Figure 2: Detailed Block Diagram

GENERAL DESCRIPTION

The ADuC702x is fully integrated, 1MSPS, 12-bit data acquisition system incorporating a high performance multi-channel ADC, a 16/32-bit MCU and Flash/EE Memory on a single chip.

The ADC consists of up to 12 single-ended inputs. An additional 4 inputs are available but are multiplexed with the 4 DAC output pins. The 4 DAC outputs are only available on certain models of the ADuC702x, though in many cases where the DAC is not present this pin can still be used as an additional ADC input, giving a maximum of 16 ADC input channels. The ADC can operate in single-ended or differential input modes. The ADC input voltage is 0 to V_{REF} . Low drift bandgap reference, temperature sensor and voltage comparator complete the ADC peripheral set.

The ADuC702x also integrates 4 buffered voltage output DACs on-chip. The DAC output range is programmable to one of three voltage ranges.

The device operates from an on-chip oscillator and PLL generating an internal high-frequency clock of 45 MHz. This clock is routed through a programmable clock divider from which the MCU core clock operating frequency is generated. The microcontroller core is an ARM7TDMI, 16/32-bit RISC machine, offering up to 45 MIPS peak performance. 62k Bytes of non-volatile Flash/EE are provided on-chip as well as 8k Bytes of SRAM. Both the Flash/EE and SRAM memory arrays are mapped into a single linear array.

On-chip factory firmware supports in-circuit serial download via the UART and JTAG serial interface ports while non-intrusive emulation is also supported via the JTAG interface. These features are incorporated into a low-cost QuickStart Development System supporting this MicroConverter family.

The parts operate from 2.7V to 3.6V and are specified over an industrial temperature range of -40°C to 85°C. When operating at 45MHz the power dissipation is 300mW. The ADuC702x is available in a variety of memory models and packages. These are detailed on page 9.

OVERVIEW OF THE ARM7TDMI CORE

The ARM7 core is a 32-bit Reduced Instruction Set Computer (RISC). It uses a single 32-bit bus for instruction and data. The length of the data can be 8, 16 or 32 bits and the length of the instruction word is 32 bits.

The ARM7TDMI is an ARM7 core with 4 additional features:

- T support for the Thumb (16 bit) instruction set.
- D support for debug
- M support for long multiplies
- I include the EmbeddedICE module to support embedded

system debugging.

Thumb mode (T)

An ARM instruction is 32-bits long. The ARM7TDMI processor supports a second instruction set that has been compressed into 16-bits, the Thumb instruction set. Faster execution from 16-bit memory and greater code density can usually be achieved by using the Thumb instruction set instead of the ARM instruction set, which makes the ARM7TDMI core particularly suitable for embedded applications.

However the Thumb mode has two limitations:

- Thumb code usually uses more instructions for the same job, so ARM code is usually best for maximising the performance of the time-critical code.
- The Thumb instruction set does not include some instructions that are needed for exception handling, so ARM code needs to be used for exception handling.

See ARM7TDMI User Guide for details on the core architecture, the programming model and both the ARM and ARM Thumb instruction sets.

Long Multiply (M)

The ARM7TDMI instruction set includes four extra instructions which perform 32-bit by 32-bit multiplication with 64-bit result and 32-bit by 32-bit multiplication-accumulation (MAC) with 64-bit result.

EmbeddedICE (I)

EmbeddedICE provides integrated on-chip support for the core. The EmbeddedICE module contains the breakpoint and watchpoint registers which allow code to be halted for debugging purposes. These registers are controlled through the JTAG test port.

When a breakpoint or watchpoint is encountered, the processor halts and enters debug state. Once in a debug state, the processor registers may be inspected as well as the Flash/EE, the SRAM and the Memory Mapped Registers.

Exceptions

ARM supports five types of exceptions, and a privileged processing mode for each type. The five type of exceptions are:

- Normal interrupt or IRQ. It is provided to service general-purpose interrupt handling of internal and external events
- Fast interrupt or FIQ. It is provided to service data transfer or communication channel with low latency. FIQ has priority over IRQ
- Memory abort
- Attempted execution of an undefined instruction

- Software interrupt (SWI) instruction which can be used to make a call to an operating system.

Typically the programmer will define interrupts as IRQ but for higher priority interrupt, i.e. faster response time, the programmer can define interrupt as FIQ.

ARM Registers

ARM7TDMI has a total of 37 registers, of which 31 are general purpose registers and six are status registers. Each operating mode has dedicated banked registers.

When writing user-level programs, 15 general purpose 32-bit registers (r0 to r14), the program counter (r15) and the current program status register (CPSR) are usable. The remaining registers are used only for system-level programming and for exception handling.

When an exception occurs, some of the standard register are replaced with registers specific to the exception mode. All exception modes have replacement banked registers for the stack pointer (r13) and the link register (r14) as represented in Figure 3. The fast interrupt mode has more registers (8 to 12) for fast interrupt processing, so that the interrupt processing can begin without the need to save or restore these registers and thus save critical time in the interrupt handling process.

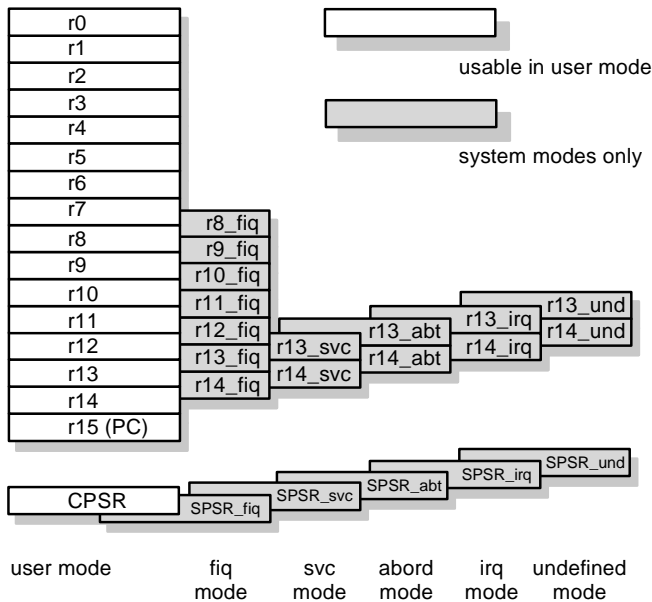

Figure 3: register organisation

More information relative to the programmer's model and the ARM7TDMI core architecture can be found in the following documents from ARM:

- DDI0029G, ARM7TDMI Technical Reference Manual.
- DDI0100E, ARM Architecture Reference Manual.

Interrupt latency

The worst case latency for an FIQ consists of the longest time the request can take to pass through the synchronizer, plus the time for the longest instruction to complete (the longest instruction is an LDM) which loads all the registers including the PC, plus the time for the data abort entry, plus the time for FIQ entry. At the end of this time, the ARM7TDMI will be executing the instruction at 0x1C (FIQ interrupt vector address). The maximum total time is 41 processor cycles, which is just over 909 nanoseconds in a system using a continuous 45 MHz processor clock. The maximum IRQ latency calculation is similar, but must allow for the fact that FIQ has higher priority and could delay entry into the IRQ handling routine for an arbitrary length of time.

The minimum latency for FIQ or IRQ interrupts is five cycles in total which consists of the shortest time the request can take through the synchronizer plus the time to enter the exception mode.

Note that the ARM7TDMI will always be run in ARM (32-bit) mode when in privileged modes, i.e. when executing interrupt service routines.

MEMORY ORGANISATION

The part incorporates two separate blocks of memory, 8kByte of SRAM and 64kByte of On-Chip Flash/EE memory. 62kByte of On-Chip Flash/EE memory are available to the user, and the remaining 2kBytes are reserved for the factory configured boot page. These two blocks are mapped as shown in

Figure 4.

Note that by default, after a reset, the Flash/EE memory is mirrored at address 0x00000000. It is possible to remap the SRAM at address 0x00000000 by clearing bit 0 of the REMAP MMR. This remap function is described in more details in the Flash/EE memory chapter.

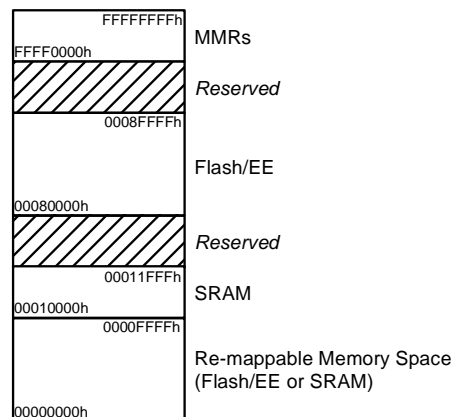

Figure 4: Physical memory map

Memory Access

The ARM7 core sees memory as a linear array of 2^{32} byte location where the different blocks of memory are mapped as outlined in

Figure 4.

The ADuC702x memory organisation is configured in little endian format: the least significant byte is located in the lowest byte address and the most significant byte in the highest byte address.

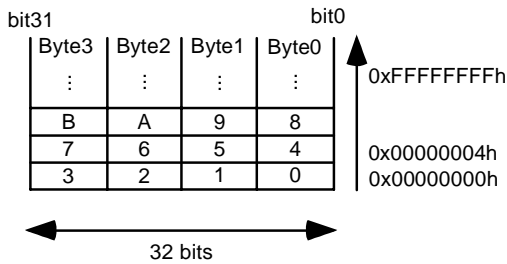

Figure 5: little endian format

Flash/EE Memory

The total 64kBytes of Flash/EE are organised as 32k X 16 bits. 31k X 16 bits are user space and 1k X 16 bits is reserved for boot loader. The page size of this Flash/EE memory is 256Bytes.

62kBytes of Flash/EE are available to the user as code and non-volatile data memory. There is no distinction between data and program as ARM code shares the same space. The real width of the Flash/EE memory is 16 bits, which means that in ARM mode (32-bit instruction), two accesses to the Flash/EE are necessary for each instruction fetch. It is therefore recommended to use Thumb mode when executing from Flash/EE memory for optimum access speed. The maximum access speed for the Flash/EE memory is 45MHz in Thumb mode and 22.5MHz in full ARM mode. More details on Flash/EE access time are outlined later in 'Execution from SRAM and Flash/EE' section of this datasheet.

SRAM

8kBytes of SRAM are available to the user, organized as 2k X 32 bits, i.e. 2kWords. ARM code can run directly from SRAM at 45MHz, given that the SRAM array is configured as a 32-bit wide memory array. More details on SRAM access time are outlined later in 'Execution from SRAM and Flash/EE' section of this datasheet.

Memory Mapped Registers

The Memory Mapped Register (MMR) space is mapped into the upper 2 pages of the Flash/EE space and accessed by indirect addressing through the ARM7 banked registers.

The MMR space provides an interface between the CPU and all on-chip peripherals. All registers except the core registers reside in the MMR area. All shaded locations shown in Figure 6 are unoccupied or reserved locations and should not be accessed by user software. Table 6 shows a full MMR memory map.

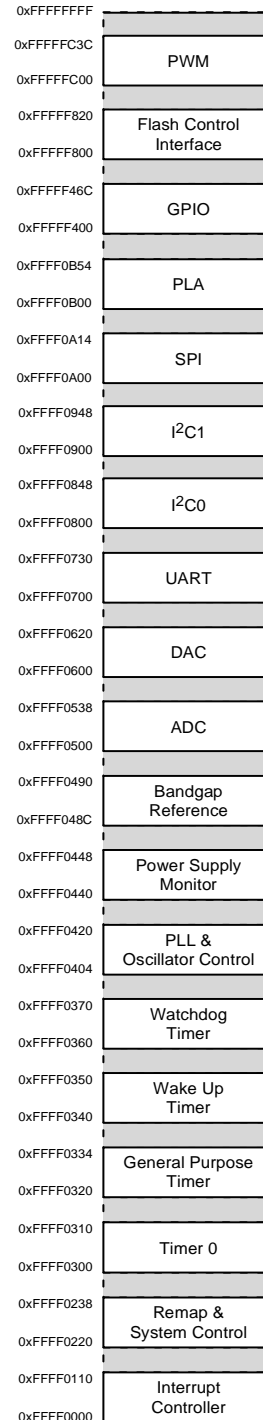

Figure 6: Memory Mapped

Table 6. Complete MMRs list

Address	Name	Byte	Access		Page
			Type	Cycle	
IRQ address base = 0xFFFF0000					
0x0000	IRQSTA	4	R	1	63
0x0004	IRQSIG	4	R	1	63
0x0008	IRQEN	4	RW	1	63
0x000C	IRQCLR	4	W	1	63
0x0010	SWICFG	4	W	1	64
0x0100	FIQSTA	4	R	1	63
0x0104	FIQSIG	4	R	1	63
0x0108	FIQEN	4	RW	1	63
0x010C	FIQCLR	4	W	1	63
System Control address base = 0xFFFF0200					
0x0220	REMAP	1	RW	1	35
0x0230	RSTSTA	1	R	1	35
0x0234	RSTCLR	1	W	1	35
Timer address base = 0xFFFF0300					
0x0300	T0LD	2	RW	2	65
0x0304	T0VAL	2	R	2	65
0x0308	T0CON	2	RW	2	65
0x030C	T0CLRI	1	W	2	65
0x0320	T1LD	4	RW	2	66
0x0324	T1VAL	4	R	2	66
0x0328	T1CON	2	RW	2	66
0x032C	T1CLRI	1	W	2	66
0x0330	T1CAP	4	RW	2	66
0x0340	T2LD	4	RW	2	67
0x0344	T2VAL	4	R	2	67
0x0348	T2CON	2	RW	2	67
0x034C	T2CLRI	1	W	2	67
0x0360	T3LD	2	RW	2	68
0x0364	T3VAL	2	R	2	68
0x0368	T3CON	2	RW	2	68
0x036C	T3CLRI	1	W	2	68
PLL base address = 0xFFFF0400					
0x0404	POWKY1	1	W	2	40
0x0408	POWCON	1	RW	2	40
0x040C	POWKY2	1	W	2	40
0x0410	PLLKY1	1	W	2	40

Address	Name	Byte	Access		Page
			Type	Cycle	
0x0414	PLLCON	1	RW	2	40
0x0418	PLLKY2	1	W	2	40
PSM address base = 0xFFFF0440					
0x0440	PSMCON	2	RW	2	38
0x0444	CMPCON	2	RW	2	38
Reference address base = 0xFFFF0480					
0x048C	REFCON	1	RW	2	30
ADC address base = 0xFFFF0500					
0x0500	ADCCON	1	RW	2	26
0x0504	ADCCP	1	RW	2	27
0x0508	ADCCN	1	RW	2	27
0x050C	ADCSTA	1	RW	2	26
0x0510	ADCDAT	4	R	2	26
0x0514	ADCRST	1	RW	2	26
0x0530	ADCGN	2	RW	2	29
0x0534	ADCOF	2	RW	2	29
DAC address base = 0xFFFF0600					
0x0600	DAC0CON	1	RW	2	36
0x0604	DAC0DAT	4	RW	2	36
0x0608	DAC1CON	1	RW	2	36
0x060C	DAC1DAT	4	RW	2	36
UART base address = 0xFFFF0700					
0x0700	COMTX	1	RW	2	51
	COMRX	1	R	2	51
	COMDIV0	1	RW	2	51
0x0704	COMIEN0	1	RW	2	52
	COMDIV1	1	R/W	2	51
0x0708	COMIID0	1	R	2	52
0x070C	COMCON0	1	RW	2	51
0x0710	COMCON1	1	RW	2	53
0x0714	COMSTA0	1	R	2	52
0x0718	COMSTA1	1	R	2	53
0x071C	COMSCR	1	RW	2	51
0x0720	COMIEN1	1	RW	2	54
0x0724	COMIID1	1	R	2	54
0x0728	COMADR	1	RW	2	51
0x072C	COMDIV2	2	RW	2	53

Address	Name	Byte	Access		Page
			Type	Cycle	
I2C0 base address = 0xFFFF0800					
0x0800	I2C0MSTA	1	R	2	58
0x0804	I2C0SSTA	1	R	2	58
0x0808	I2C0SRX	1	R	2	57
0x080C	I2C0STX	1	W	2	57
0x0810	I2C0MRX	1	R	2	57
0x0814	I2C0MTX	1	W	2	57
0x0818	I2C0CNT	1	RW	2	57
0x081C	I2C0ADR	1	RW	2	57
0x0824	I2C0BYTE	1	RW	2	57
0x0828	I2C0ALT	1	RW	2	57
0x082C	I2C0CFG	1	RW	2	57
0x0830	I2C0DIVH	1	RW	2	57
0x0834	I2C0DIVL	1	RW	2	57
0x0838	I2C0ID0	1	RW	2	57
0x083C	I2C0ID1	1	RW	2	57
0x0840	I2C0ID2	1	RW	2	57
0x0844	I2C0ID3	1	RW	2	57
I2C1 base address = 0xFFFF0900					
0x0900	I2C1MSTA	1	R	2	58
0x0904	I2C1SSTA	1	R	2	58
0x0908	I2C1SRX	1	R	2	57
0x090C	I2C1STX	1	W	2	57
0x0910	I2C1MRX	1	R	2	57
0x0914	I2C1MTX	1	W	2	57
0x0918	I2C1CNT	1	RW	2	57
0x091C	I2C1ADR	1	RW	2	57
0x0924	I2C1BYTE	1	RW	2	57
0x0928	I2C1ALT	1	RW	2	57
0x092C	I2C1CFG	1	RW	2	57
0x0930	I2C1DIVH	1	RW	2	57
0x0934	I2C1DIVL	1	RW	2	57
0x0938	I2C1ID0	1	RW	2	57
0x093C	I2C1ID1	1	RW	2	57
0x0940	I2C1ID2	1	RW	2	57
0x0944	I2C1ID3	1	RW	2	57
SPI base address = 0xFFFF0A00					
0x0A00	SPISTA	1	R	2	55

0x0A04	SPIRX	1	R	2	55
Address	Name	Byte	Access		Page
			Type	Cycle	
0x0A08	SPITX	1	W	2	55
0x0A0C	SPIDIV	1	RW	2	55
0x0A10	SPICON	2	RW	2	55
PLA base address = 0xFFFF0B00					
0x0B00	PLAELM0	2	RW	2	60
0x0B04	PLAELM1	2	RW	2	60
0x0B08	PLAELM2	2	RW	2	60
0x0B0C	PLAELM3	2	RW	2	60
0x0B10	PLAELM4	2	RW	2	60
0x0B14	PLAELM5	2	RW	2	60
0x0B18	PLAELM6	2	RW	2	60
0x0B1C	PLAELM7	2	RW	2	60
0x0B20	PLAELM8	2	RW	2	60
0x0B24	PLAELM9	2	RW	2	60
0x0B28	PLAELM10	2	RW	2	60
0x0B2C	PLAELM11	2	RW	2	60
0x0B30	PLAELM12	2	RW	2	60
0x0B34	PLAELM13	2	RW	2	60
0x0B38	PLAELM14	2	RW	2	60
0x0B3C	PLAELM15	2	RW	2	60
0x0B40	PLACLK	1	RW	2	61
0x0B44	PLAIRQ	4	RW	2	61
0x0B48	PLAADC	4	RW	2	62
0x0B4C	PLADIN	4	R	2	62
0x0B50	PLADOUT	4	RW	2	62
External Memory base address = 0xFFFFF000					
0xF000	XMCFG	1	RW	2	
0xF010	XM0CON	1	RW	2	
0xF014	XM1CON	1	RW	2	
0xF018	XM2CON	1	RW	2	
0xF01C	XM3CON	1	RW	2	
0xF020	XM0PAR	2	RW	2	
0xF024	XM1PAR	2	RW	2	
0xF028	XM2PAR	2	RW	2	
0xF02C	XM3PAR	2	RW	2	
GPIO base address = 0xFFFFF400					
0xF400	GPOCON	4	RW	1	48

0xF404	GP1CON	4	RW	1	48
0xF408	GP2CON	4	RW	1	48
0xF40C	GP3CON	4	RW	1	48
0xF410	GP4CON	4	RW	1	48
0xF420	GP0DAT	4	RW	1	49
0xF424	GP0SET	1	W	1	49
0xF428	GP0CLR	1	W	1	49
0xF430	GP1DAT	4	RW	1	49
0xF434	GP1SET	1	W	1	49
0xF438	GP1CLR	1	W	1	49
0xF440	GP2DAT	4	RW	1	49
0xF444	GP2SET	1	W	1	49
Address	Name	Byte	Access		Page
			Type	Cycle	
0xF448	GP2CLR	1	W	1	49
0xF450	GP3DAT	4	RW	1	49
0xF454	GP3SET	1	W	1	49
0xF458	GP3CLR	1	W	1	49
0xF460	GP4DAT	4	RW	1	49
0xF464	GP4SET	1	W	1	49
0xF468	GP4CLR	1	W	1	49
Flash/EE base address = 0xFFFFF800					
0xF800	FEESTA	1	R	1	32
0xF804	FEEMOD	1	RW	1	32
0xF808	FEECON	1	RW	1	32
0xF80C	FEEDAT	2	RW	1	32
0xF810	FEEADR	2	RW	1	32
0xF818	FEESIGN	3	R	1	32
0xF81C	FEEPRO	4	RW	1	33
0xF820	FEEHIDE	4	RW	1	33
PWM base address= 0xFFFFFC00					
0xFC00	PWMCON	2	RW	1	46
0xFC04	PWMSTA	2	RW	1	
0xFC08	PWMDAT0	2	RW	1	
0xFC0C	PWMDAT1	2	RW	1	
0xFC10	PWMCFG	2	RW	1	
0xFC14	PWMCH0	2	RW	1	46
0xFC18	PWMCH1	2	RW	1	46
0xFC1C	PWMCH2	2	RW	1	46
0xFC20	PWMEN	2	RW	1	47

0xFC24	PWMDAT2	2	RW	1	
--------	---------	---	----	---	--

The 'Access' column corresponds to the access time reading or writing a MMR. It depends on the AMBA (Advanced Microcontroller Bus Architecture) bus used to access the peripheral. The processor has two AMBA busses, AHB (Advanced High-performance Bus) used for system modules and APB (Advanced Peripheral Bus) used for lower performance peripheral.

ADC CIRCUIT INFORMATION

GENERAL OVERVIEW

The Analog Digital Converter (ADC) incorporates a fast, multi-channel, 12-bit ADC. It can operate from 2.7V to 3.6V supplies and is capable of providing a throughput of up to 1MSPS when the clock source is 45MHz. This block provides the user with multi-channel multiplexer, differential track-and-hold, on-chip reference and ADC.

The ADC consists of a 12-bit successive-approximation converter based around two capacitor DACs. It can operate in one of three different modes, depending on the input signal configuration :

- *fully differential mode*, for small and balanced signals
- *single-ended mode*, for any single-ended signals
- *pseudo-differential mode*, for any single-ended signals, taking advantage of the common mode rejection offered by the pseudo differential input.

The converter accepts an analog input range of 0 to V_{REF} when operating in single-ended mode or pseudo-differential mode. In fully differential mode, the input signal must be balanced around a common mode voltage V_{CM} , in the range 0V to AV_{DD} and with a maximum amplitude of $2V_{REF}$ (see Figure 7).

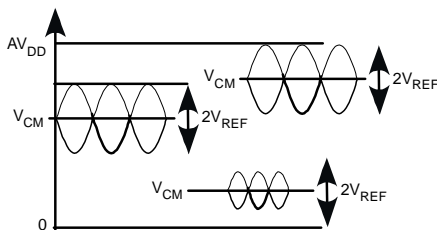

Figure 7: examples of balanced signals for fully differential mode

A high precision, low drift, and factory calibrated 2.5 V reference is provided on-chip. An external reference can also be connected as described later.

Single or continuous conversion modes can be initiated in software. An external $CONV_{START}$ pin, an output generated from the on-chip PLA or a Timer1 or a Timer2 overflow can also be used to generate a repetitive trigger for ADC conversions.

A voltage output from an on-chip bandgap reference proportional to absolute temperature can also be routed through the front end ADC multiplexer (effectively an additional ADC channel input) facilitating an internal temperature sensor channel, measuring die temperature to an accuracy of $\pm 3^{\circ}C$.

ADC TRANSFER FUNCTION

Pseudo-differential and single-ended modes

In pseudo-differential or single-ended mode, the input range is 0 V to V_{REF} . The output coding is straight binary in pseudo differential and single-ended modes with $1\text{ LSB} = FS/4096$ or $2.5\text{ V}/4096 = 0.61\text{ mV}$ or $610\text{ }\mu\text{V}$ when $V_{REF} = 2.5\text{ V}$. The ideal code transitions occur midway between successive integer LSB values (i.e. $1/2\text{ LSB}$, $3/2\text{ LSBs}$, $5/2\text{ LSBs}$, . . . , $FS - 3/2\text{ LSBs}$). The ideal input/output transfer characteristic is shown in Figure 8.

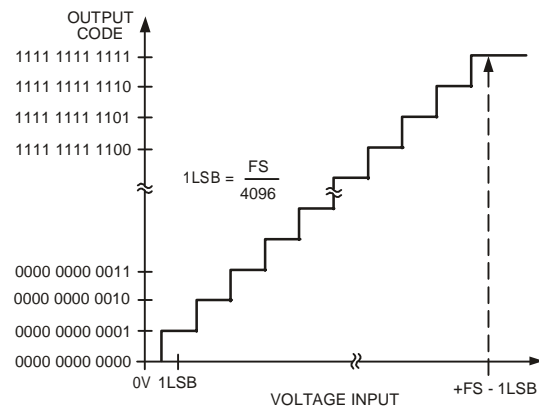

Figure 8: ADC transfer function in pseudo differential mode or single-ended mode

Fully differential mode

The amplitude of the differential signal is the difference between the signals applied to the V_{IN+} and V_{IN-} pins (i.e., $V_{IN+} - V_{IN-}$). The maximum amplitude of the differential signal is therefore $-V_{REF}$ to $+V_{REF}$ p-p (i.e. $2 \times V_{REF}$). This is regardless of the common mode (CM). The common mode is the average of the two signals, i.e. $(V_{IN+} + V_{IN-})/2$ and is therefore the voltage that the two inputs are centred on. This results in the span of each input being $CM \pm V_{REF}/2$. This voltage has to be set up externally and its range varies with V_{REF} , (see driving the ADC).

The output coding is two's complement in fully differential mode with $1\text{ LSB} = 2V_{REF}/4096$ or $2 \times 2.5\text{ V}/4096 = 1.22\text{ mV}$ when $V_{REF} = 2.5\text{ V}$. The designed code transitions occur midway between successive integer LSB values (i.e., $1/2\text{ LSB}$, $3/2\text{ LSBs}$, $5/2\text{ LSBs}$, . . . , $FS - 3/2\text{ LSBs}$). The ideal input/output transfer characteristic is shown in Figure 9.

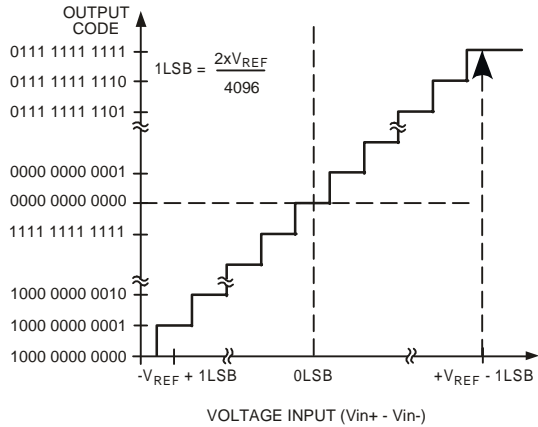

Figure 9: ADC transfer function in differential mode

TYPICAL OPERATION

Once configured via the ADC control and channel selection registers, the ADC will convert the analog input and provide a 12-bit result in the ADC data register.

The top 4 bits are the sign bits and the 12-bit result is placed from bit 16 to 27 as shown in Figure 10. Again, it should be noted that in fully differential mode, the result is represented in two's complement format, and in pseudo differential and single-ended mode, the result is represented in straight binary format.

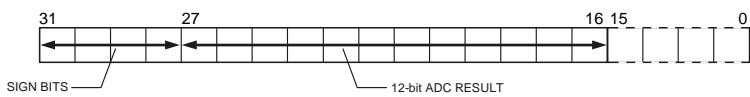

Figure 10: ADC Result Format

The same format is used in DACxDAT, simplifying the software.

ADC MMRS interface

The ADC is controlled and configured via a number of MMRS that are listed below and described in detail in the following pages:

- **ADCCON:** ADC Control Register allows the programmer to enable the ADC peripheral, to select the mode of operation of the ADC, either Single-ended, pseudo-differential or fully differential mode and the conversion type. This MMR is described Table 7.
- **ADCCP:** ADC positive Channel selection Register
- **ADCCN:** ADC negative Channel selection Register
- **ADCSTA:** ADC Status Register, indicates when an ADC conversion result is ready. The ADCSTA register contains only one bit, bit (bit 0), representing the status of the ADC. This bit is set at the end of an ADC conversion generating an ADC interrupt, it is cleared automatically by reading the ADCDAT MMR. When the ADC is performing a conversion, the status of the ADC can be read externally via the ADCBusy pin. This pin is high during a conversion. When the conversion is finished, ADCBusy goes back low. This information can be available on P0.3 (see chapter on GPIO) if enabled in ADCCON register.
- **ADCDAT:** ADC Data Result Register, hold the 12-bit ADC result as shown Figure 10
- **ADCRST:** ADC Reset Register. Resets all the ADC registers to their default value.
- **ADCOF:** Offset calibration register. 10-bit register
- **ADCGN:** Gain calibration register. 10-bit register

Table 7: ADCCON MMR Bit Designations

Bit	Description
7	Enable Conversion Set by the user to enable conversion mode Cleared by the user to disable conversion mode
6	Enable ADC _{BUSY} Set by the user to enable the ADC _{BUSY} pin Cleared by the user to disable the ADC _{BUSY} pin
5	ADC power control: Set by the user to place the ADC in normal mode, the ADC must be powered up for at least 500uS before it will convert correctly. Cleared by the user to place the ADC in power-down mode
4-3	Conversion Mode: 00 Single Ended Mode 01 Differential Mode 10 Pseudo-Differential Mode 11 Reserved
2-0	Conversion Type:

000	Enable CONV _{START} pin (pin 31) as a conversion input
001	Enable timer1 as a conversion input
010	Enable timer0 as a conversion input
011	Single software conversion
100	Continuous software conversion
101	PLA conversion
Other	<i>Reserved</i>

Table 8: ADCCP* MMR bit designation

Bit	Description
7-5	<i>Reserved</i>
4-0	Positive Channel Selection Bits
00000	ADC0
00001	ADC1
00010	ADC2
00011	ADC3
00100	ADC4
00101	ADC5
00110	ADC6
00111	ADC7
01000	ADC8
01001	ADC9
01010	ADC10
01011	ADC11
01100	DAC0/ADC12
01101	DAC1/ADC13
01110	DAC2/ADC14
01111	DAC3/ADC15
10000	Temperature sensor
10001	AGND
10010	Reference
10011	AVDD/2
Others	<i>Reserved</i>

Table 9: ADCCN* MMR bit designation

Bit	Description
7-5	<i>Reserved</i>
4-0	Negative Channel Selection Bits
00000	ADC0
00001	ADC1
00010	ADC2
00011	ADC3
00100	ADC4
00101	ADC5
00110	ADC6
00111	ADC7
01000	ADC8
01001	ADC9
01010	ADC10
01011	ADC11
01100	DAC0/ADC12
01101	DAC1/ADC13
01110	DAC2/ADC14
01111	DAC3/ADC15
10000	Reference
Others	<i>Reserved</i>

* ADC and DAC channel availability depends on part model. See page 9 for details.

CONVERTER OPERATION

The ADC incorporates a successive approximation (SAR) architecture involving a charge-sampled input stage. This architecture is described below for the three different modes of operation.

Differential mode

The ADuC702x contains a successive approximation ADC based on two capacitive DACs. Figure 11 and Figure 12 show simplified schematics of the ADC in acquisition and conversion phase, respectively. The ADC is comprised of control logic, a SAR, and two capacitive DACs. In Figure 11 (the acquisition phase), SW3 is closed and SW1 and SW2 are in Position A, the comparator is held in a balanced condition, and the sampling capacitor arrays acquire the differential signal on the input.

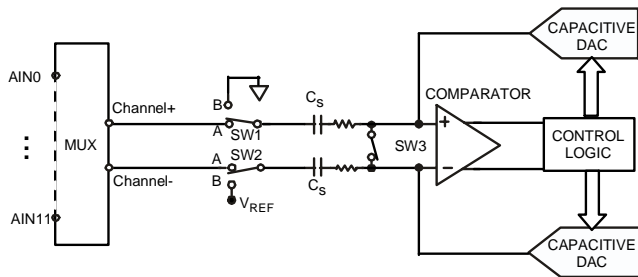

Figure 11: ADC acquisition phase

When the ADC starts a conversion (Figure 12), SW3 will open and SW1 and SW2 will move to Position B, causing the comparator to become unbalanced. Both inputs are disconnected once the conversion begins. The control logic and the charge redistribution DACs are used to add and subtract fixed amounts of charge from the sampling capacitor arrays to bring the comparator back into a balanced condition. When the comparator is rebalanced, the conversion is complete. The control logic generates the ADC's output code. The output impedances of the sources driving the V_{IN+} and V_{IN-} pins must be matched; otherwise, the two inputs will have different settling times, resulting in errors.

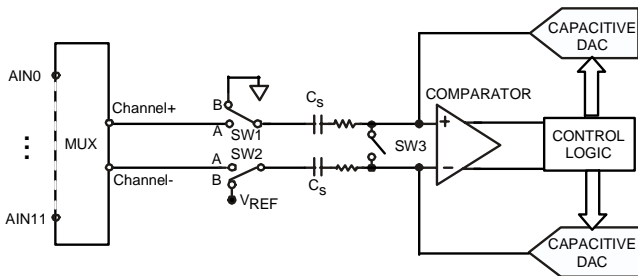

Figure 12: ADC conversion phase

Pseudo-differential mode

In pseudo-differential mode, Channel- is linked to the V_{IN-} pin

of the ADuC702x and SW2 switches between A (Channel-) and B (V_{REF}). V_{IN-} pin must be connected to Ground or a low voltage ($<?mV$). The input signal on V_{IN+} can then vary from V_{IN-} to $V_{REF} + V_{IN-}$.

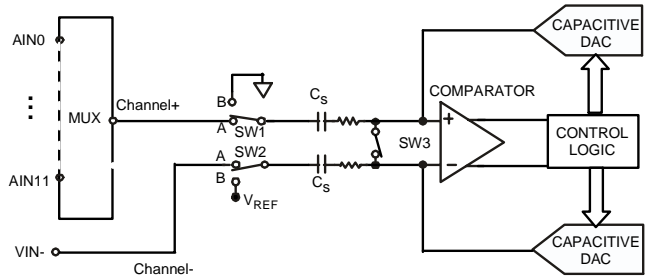

Figure 13: ADC in pseudo-differential mode

Single-ended mode

In Single-ended mode, SW2 is always connected internally to ground. The V_{IN-} pin can be floating. The input signal range on V_{IN+} is $0V$ to V_{REF} .

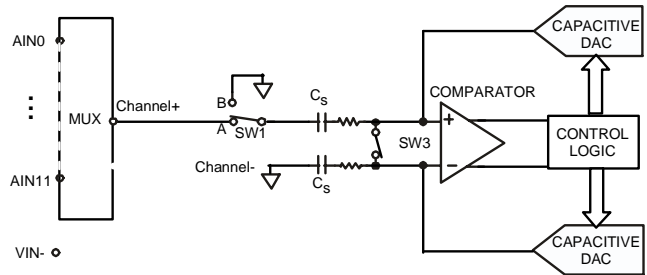

Figure 14: ADC in single-ended mode

Analog Input Structure

Figure 15 shows the equivalent circuit of the analog input structure of the ADC. The four diodes provides ESD protection for the analog inputs. Care must be taken to ensure that the analog input signals never exceed the supply rails by more than 300 mV. This would cause these diodes to become forward biased and start conducting into the substrate. These diodes can conduct up to 10 mA without causing irreversible damage to the part.

The capacitors C1 in Figure 15 are typically 4 pF and can primarily be attributed to pin capacitance. The resistors are lumped components made up of the ON resistance of the switches. The value of these resistors is typically about 100Ω . The capacitors, C2, are the ADC's sampling capacitors and have a capacitance of 16 pF typically.

For AC applications, removing high-frequency components from the analog input signal is recommended by the use of an RC low-pass filter on the relevant analog input pins. In applications where harmonic distortion and signal-to-noise ratio are critical, the analog input should be driven from a low

impedance source. Large source impedances will significantly affect the AC performance of the ADC. This may necessitate the use of an input buffer amplifier. The choice of the op amp will be a function of the particular application.

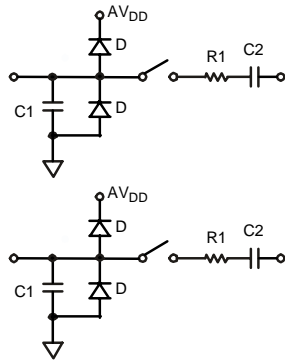

Figure 15: Equivalent Analog Input Circuit
Conversion Phase: Switches Open
Track Phase: Switches Closed

When no amplifier is used to drive the analog input, the source impedance should be limited to values lower than 1 kΩ . The maximum source impedance will depend on the amount of total harmonic distortion (THD) that can be tolerated. The THD will increase as the source impedance increases and the performance will degrade.

DRIVING THE ANALOG INPUTS

Internal or external reference can be used for the ADC. In differential mode of operation, there are restrictions on common mode input signal (V_{CM}) that are dependant on reference value and supply voltage used to ensure that the signal remains within the supply rails. Table 10 gives some calculated $V_{CM\ min}$ $V_{CM\ max}$ for some conditions.

Table 10: V_{CM} ranges

AVDD	VREF	$V_{CM\ min}$	$V_{CM\ max}$	Signal Peak-Peak
3.3V	2.5V	1.25V	2.05V	2.5V
	2.048V	1.024V	2.276V	2.048V
	1.25	0.75V	2.55V	1.25
3.0V	2.5V	1.25V	1.75V	2.5V
	2.048V	1.024V	1.976V	2.048V
	1.25	0.75V	2.25V	1.25

ADC CALIBRATION

System calibration or device calibration are performed in software. Two 10-bit registers are available for calibration,

ADCOF and ADCGN.

For offset error correction, either an external pin must be tied to AGND (system calibration) or the internal AGND channel must be selected (device calibration). A software loop must be implemented to tweak the value in ADCOF register each time until the transition of ADCDAT reads code 0 to 1. Offset error correction is done digitally and has a resolution of 0.25 lsb and a range of +/- 3.125% of VREF.

For gain error correction, either an external pin must be tied to VREF (system calibration) or the internal reference channel must be selected (device calibration). A software loop must be implemented to tweak the value in ADCGN register each time until the transition of ADCDAT reads code 4094 to 4095. Similar to the offset calibration, the gain calibration resolution is 0.25 lsb with a range of +/- 3% of VREF.

TEMPERATURE SENSOR

The ADuC702x provides a voltage output from an on-chip bandgap reference proportional to absolute temperature. It can also be routed through the front end ADC multiplexer (effectively an additional ADC channel input) facilitating an internal temperature sensor channel, measuring die temperature to an accuracy of $\pm 3^{\circ}C$.

BANDGAP REFERENCE

The ADuC702x provides an on-chip bandgap reference of 2.5V, which can be used for the ADC and for the DAC. This internal reference also appears on the V_{REF} pin. When using the internal reference, a capacitor of 0.47 μ F must be connected from the external V_{REF} pin to AGND, to ensure stability and fast response during ADC conversions. This reference can also be connected to an external pin (VREF) and used as a reference for other circuits in the system. An external buffer would be required because of the low drive capability of the VREF output. A programmable option also allows an external reference input on the V_{REF} pin.

The bandgap reference interface consists on a 8-bit MMR, REFCON described in

Table 11.

Table 11: REFCON MMR bit designations

Bit	Description
7-2	<i>Reserved</i>
1	Internal reference output enable <i>Cleared</i> by user to place the internal reference in normal mode and use it for ADC conversions <i>Set</i> by user to place the internal reference in power-down mode and use an external reference
0	Internal reference output enable <i>Set</i> by user to connect the internal 2.5V reference to the VREF pin. The reference can be used for external component but will need to be buffered. <i>Cleared</i> by user to disconnect the reference from the VREF pin.

NONVOLATILE FLASH/EE MEMORY

FLASH/EE MEMORY OVERVIEW

The ADuC702x incorporates Flash/EE memory technology on-chip to provide the user with non-volatile, in-circuit reprogrammable memory space.

Like EEPROM, Flash memory can be programmed in-system at a byte level, although it must first be erased; the erase being performed in page blocks. Thus, Flash memory is often and more correctly referred to as Flash/EE memory.

Overall, Flash/EE memory represents a step closer to the ideal memory device that includes non-volatility, in-circuit programmability, high density, and low cost. Incorporated in the ADuC702x, Flash/EE memory technology allows the user to update program code space in-circuit, without the need to replace one time programmable (OTP) devices at remote operating nodes.

FLASH/EE MEMORY AND THE ADUC702X

The ADuC702x contains a 64 kByte array of Flash/EE Memory. The lower 62 Kbytes is available to the user and the upper 2 kBytes of this Flash/EE program memory array contain permanently embedded firmware, allowing in circuit serial download. These 2 Kbytes of embedded firmware also contain a power-on configuration routine that downloads factory calibrated coefficients to the various calibrated peripherals (ADC, temperature sensor, bandgap references and so on). This 2 kByte embedded firmware is hidden from user code.

The 62kBytes of Flash/EE memory can be programmed in-circuit, using the serial download mode or the JTAG mode provided or via parallel programming.

(1) Serial Downloading (In-Circuit Programming)

The ADuC702x facilitates code download via the standard UART serial port or via the I2C port. The ADuC702x will enter serial download mode after a reset or power cycle if the BM pin is pulled low through an external 1kOhm resistor. Once in serial download mode, the user can download code to the full 62kBytes of Flash/EE memory while the device is in circuit in its target application hardware. A PC serial download executable is provided as part of the development system for serial downloading via the UART. An application note is available at www.analog.com/microconverter describing the protocol for serial downloading via the UART and I2C.

(2) Parallel Programming

The parallel programming protocol allows the on-chip Flash/EE memory be programmed by industry standard third party programmers.

(3) JTAG access

The JTAG protocol uses the on-chip JTAG interface to facilitate code download and debug.

FLASH/EE MEMORY SECURITY

The 62kByte of Flash/EE memory available to the user can be read and write protected.

Bit 31 of the FEEPRO/FEEHIDE MMR protects the 62kBytes from being read through JTAG and also in parallel programming mode. The other 31 bits of this register protect in writing, each bit protects 4 pages, i.e. 2kBytes. Write protection is activated for all type of access.

There are two levels of protection:

- Protection can be set and removed by writing directly into FEEHIDE MMR.
- FEEPRO can be protected by a key to avoid direct access to FEEPRO. The key is saved once and must be entered again to modify FEEPRO. After three unsuccessful attempts to access FEEPRO with an invalid key, a mass erase will occur. A mass erase will set the key back to 0xFFFF but will also erase all the user code.

Sequence to write the key:

1. Enter an address in FEEADR.
2. Do a single READ command, wait for the read to be successful by monitoring FEESTA.
3. Run a verify command.
4. Write the bit in FEEPRO corresponding to the page to be protected.
5. Enable key protection by setting bits 7 to 4 of FEEMOD.
6. Write a 32 bit key in FEEADR, FEEDAT
7. Run the write key command 0x0C in FEECON, wait for the read to be successful by monitoring FEESTA.

To remove or modify the protection the same sequence can be used with a modified value of FEEPRO.

The sequence above is illustrated in the following example, this protects writing pages 4 to 7 of the FLASH:

```
FEEADR = 0x800;           //Any address,
FEECON=0x01;             //Read command
while (!(FEESTA & 0x01)){} //Wait for read
FEECON=0x04;             //Verify Command
FEEPRO=0xFFFFFFF0;      //Protect pages 4 to 7
FEEMOD=(FEEMOD & 0xF0); //Write key enable
FEEADR=0xAA55;           //16 bit key value
FEEDAT=0xAA55;           //16 bit key value
FEECON= 0x0C;            // Write key command
while (!(FEESTA & 0x01)){} //Wait for command
```

FLASH/EE CONTROL INTERFACE

Serial, parallel and JTAG programming use the Flash/EE Control Interface, which includes seven MMRs:

- **FEESTA**: read only register, reflects the status of the Flash Control Interface
- **FEEMOD**: sets the operating mode of the Flash Control Interface
- **FEECON**: 8-bit command register. The commands are described Table 14

- **FEEDAT**: 16-bit data register.
- **FEEADR**: 16-bit address register.
- **FEESIGN**: 24-bit code signature
- **FEEPRO**: protection following subsequent reset MMR. Requires software key. See description Table 15
- **FEEHIDE**: Immediate Protection MMR. Does not require any software keys. See description Table 15

Table 12: FEESTA MMR bit designations

Bit	Description
15-6	<i>Reserved</i>
5	Burst command enable <i>Set</i> when the command is a burst command: 0x07, 0x08 or 0x09 <i>Cleared</i> when other command
4	<i>Reserved</i>
3	Flash interrupt status bit <i>Set</i> automatically when an interrupt occurs, i.e. when a command is complete and the Flash/EE interrupt enable bit in the FEEMOD register is set <i>Cleared</i> when reading FEESTA register
2	Flash/EE controller busy <i>Set</i> automatically when the controller is busy <i>Cleared</i> automatically when the controller is not busy
1	Command fail <i>Set</i> automatically when a command completes unsuccessfully <i>Cleared</i> automatically when reading FEESTA register
0	Command complete <i>Set</i> by MicroConverter when a command is complete <i>Cleared</i> automatically when reading FEESTA register

Table 13: FEEMOD MMR bit designations

Bit	Description
7-5	<i>Reserved</i>
4	Flash/EE interrupt enable: <i>Set</i> by user to enable the Flash/EE interrupt. The interrupt will occur when a command is complete. <i>Cleared</i> by user to disable the Flash/EE interrupt
3-0	<i>Reserved</i>

Table 14: command codes in FEECON

Code	command	Description
0x00*	Null	Idle state
0x01*	Single Read	Load FEEDAT with the 16-bit data indexed by FEEADR
0x02*	Single Write	Write FEEDAT at the address pointed by FEEADR. This operation takes 20µs.
0x03*	Erase-Write	Erase the page indexed by FEEADR and write FEEDAT at the location pointed by FEEADR. This operation takes 20ms
0x04*	Single Verify	Compare the contents of the location pointed by FEEADR to the data in FEEDAT. The result of the comparison is returned in FEESTA bit 1
0x05*	Single Erase	Erase the page indexed by FEEADR

0x06*	Mass erase	Erase 62kByte of user space. The 2kByte of kernel are protected. This operation takes 2.48s To prevent accidental execution a command sequence is required to execute this instruction, this is described below.
0x07	Burst read	Default command. No write is allowed. This operation takes 2 cycles
0x08	Burst read-write	Write can handle a maximum of 8 data of 16 bits and takes a maximum of 8 x 20 μs
0x09	Erase Burst read-write	Will automatically erase the page indexed by the write, allow to write pages without running an erase command. This command takes 20 ms to erase the page + 20 μs per data to write
0x0A	Burst termination	Stops the running burst to allow execution from Flash/EE immediately
0x0B	Signature	Give a signature of the 64kBytes of Flash/EE in the 24-bit FEESIGN MMR. This operation takes 32778 clock cycles.
0x0C	Protect	This command can be run only once. The value of FEEPRO is saved and can be removed only with a mass erase (0x06) or with the key
0x0D	Reserved	Reserved
0x0E	Reserved	Reserved
0x0F	Ping	No operation, interrupt generated

* The FEECON will always read 0x07 immediately after execution of any of these commands.

Command Sequence for executing a Mass Erase

```
FEEADR = 0x800;           //Any address
FEECON=0x01;             //Read command
while (!(FEESTA & 0x01)){} //Wait for read
FEECON=0x04;             //Verify Command
FEEDAT=0x06;            //Mass erase enable
FEECON=0x06;            //Mass erase command
```

Table 15: FEEPRO and FEEHIDE MMR bit designations

Bit	Description
31	Read protection <i>Cleared</i> by user to protect all code <i>Set</i> by user to allow reading the code
30-0	Write protection for pages 123 to 120, for pages 119 to 116... and for pages 0 to 3 <i>Cleared</i> by user to protect the pages in writing <i>Set</i> by user to allow writing the pages

EXECUTION TIME FROM SRAM AND FLASH/EE

This chapter describes SRAM and Flash/EE access times during execution for applications where execution time is critical.

Execution from SRAM

Fetching instruction from SRAM takes one clock cycle as the access time of the SRAM is 2ns and a clock cycle is 22ns minimum. However, if the instruction involve reading or writing data to memory, one extra cycle must be added if the data is in SRAM, or three cycle if the data is in Flash/EE, one cycle to execute the instruction and two cycles to get the 32-bit data from Flash/EE. A control flow instruction, for example a branch instruction will take one cycle to fetch but also two cycle to fill the pipeline with the new instructions.

Execution from Flash/EE

Because the Flash/EE width is 16-bit and access time for 16-bit words is 22ns, execution from Flash/EE cannot be done in one cycle as from SRAM when CD bit =0. Also some dead times are needed before accessing data for any value of CD bits.

In ARM mode, where instructions are 32 bits, two cycles are needed to fetch any instruction when CD = 0 and in Thumb mode, where instructions are 16 bits, one cycle is needed to fetch any instruction.

Timing is identical in both mode when executing instructions that involve using the Flash/EE for data memory. If the instruction to be executed is a control flow instruction, an extra cycle is needed to decode the new address of the program counter and then four cycles are needed to fill the pipe-line. A data processing instruction involving only core register doesn't require any extra clock cycle but if it involves data in Flash/EE, an extra clock cycle is needed to decode the address of the data and two cycles to get the 32-bit data from Flash/EE. An extra

cycle must also be added before fetching another instruction. Data transfer instructions are more complex and are summarised in Table 16.

Table 16: execution cycles in ARM/Thumb mode

Instructions	Fetch cycles	Dead time	Data access	Dead time
LD	2/1	1	2	1
LDH	2/1	1	1	1

LDM/PUSH	2/1	N	2 x n	N
STR	2/1	1	2 x 20µs	1
STRH	2/1	1	20µs	1
STRM/POP	2/1	N	2 x N x 20µs	N

With $1 < N \leq 16$, N number of data to load or store in the multiple load/store instruction.

The SWAP instruction combines a LD and STR instruction with only one fetch giving a total of 8 cycles plus 40µs.

RESET AND REMAP

The ARM exception vectors are all situated at the bottom of the memory array, from address 0x00000000 to address 0x00000020 as shown Figure 16.

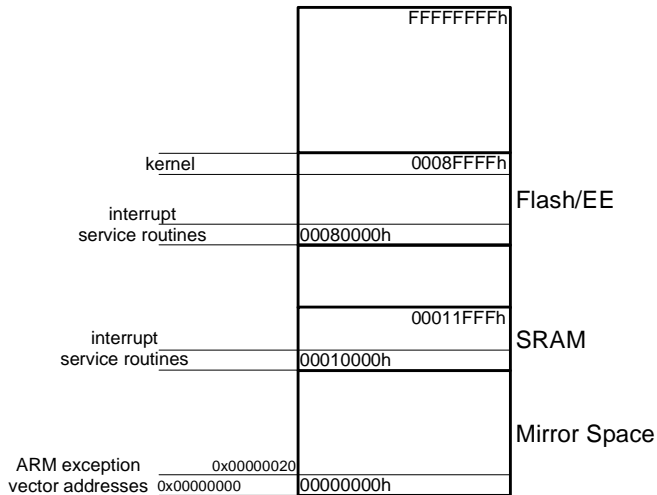

Figure 16: remap for exception execution

By default and after any reset, the Flash/EE is mirrored at the bottom of the memory array. The remap function allows the programmer to mirror the SRAM at the bottom of the memory array, facilitating execution of exception routines from SRAM instead of from Flash/EE. This means exceptions are executed twice faster, exception being executed in ARM mode (32 bit) and the SRAM being 32-bit wide instead of 16-bit wide Flash/EE memory.

Remap operation

When a reset occurs on the ADuC702x, execution starts automatically in factory programmed internal configuration code. This so called kernel is hidden and cannot be accessed by user code. If the ADuC702x is in normal mode (BM pin is high), it will execute the power-on configuration routine of the kernel and then jump to the reset vector address, 0x00000000, to execute the users reset exception routine.

Because the Flash/EE is mirrored at the bottom of the memory array at reset, the reset interrupt routine must always be written in Flash/EE.

The remap is done from Flash/EE by setting bit0 of the REMAP register. Precaution must be taken to execute this command from Flash/EE, above address 0x00080020, and not from the bottom of the array as this will be replaced by the SRAM.

This operation is reversible: the Flash/EE can be remapped at address 0x00000000 by clearing Bit0 of the REMAP MMR. Precaution must again be taken to execute the remap function from outside the mirrored area. Any kind of reset will remap the Flash /EE memory at the bottom of the array. The remap can be executed only once.

Reset

There are four kinds of reset: external reset, Power-on-reset, watchdog expiation and software force. The RSTSTA register indicates the source of the last reset and RSTCLR allows to clear the RSTSTA register. These registers can be used during a reset exception service routine to identify the source of the reset. If RSTSTA is null, the reset was external.

Table 17: REMAP MMR bit designations

Bit	Name	Description
0	Remap	Remap Bit. Set by the user to remap the SRAM to address 0x00000000. Cleared by user to remap the Flash/EE memory to address 0x00000000. Also cleared after reset

Table 18: RSTSTA MMR bit designations

Bit	Description
7-3	Reserved
2	Software reset Set by user to force a software reset. Cleared by setting the corresponding bit in RSTCLR
1	Watchdog timeout Set automatically when a watchdog timeout occurs Cleared by setting the corresponding bit in RSTCLR
0	Power-on-reset Set automatically when a power-on-reset occurs Cleared by setting the corresponding bit in RSTCLR

OTHER ANALOG PERIPHERALS

DAC

The ADuC702x incorporate dual 12-bit voltage output DACs on-chip. Each DAC has a rail-to-rail voltage output buffer capable of driving 5k Ω /100pF. Each buffer can be bypassed.

Each DAC has three selectable ranges, 0V to V_{REF} (internal bandgap 2.5V reference), 0V to DAC_{REF} (pin 56) and 0V to AV_{DD} . DAC_{REF} is equivalent to an external reference for the

DAC. The signal range is 0V to AV_{DD} .

DAC MMRs interface

Each DAC is configurable independently through a Control register and a Data register. These two registers are identical for the four DACs and only $DAC0CON$ and $DAC0DAT$ will be described in detail.

Table 19: DAC0CON MMR bit designations

Bit	Name	Description
6	DACBYP	Buffer bypass bit: Set by the user to bypass the output buffer. Cleared by user to buffer the DAC output. By default the DAC is buffered.
5	DACCLK	DAC update rate: Set by the user to update the DAC using timer1. Cleared by user to update the DAC using the core clock.
4	DACCLR	DAC clear bit: Set by the user to enable normal DAC operation. Cleared by user to reset data register of the DAC to zero.
3		Reserved This bit should be left at '0'
2		Reserved This bit should be left at '0'
1-0		DAC range bits 00 Power down mode. The DAC output is in tri-state 01 0- DAC_{REF} range 10 0- V_{REF} (2.5V) range 11 0- AV_{DD} range

Table 20: DAC0DAT MMR bit designations

Bit	Description
6	Reserved
23-12	12-bit data for DAC0
11-0	Reserved

Using the DACs

The on-chip DAC architecture consists of a resistor string DAC followed by an output buffer amplifier, the functional equivalent of which is illustrated in Figure 17.

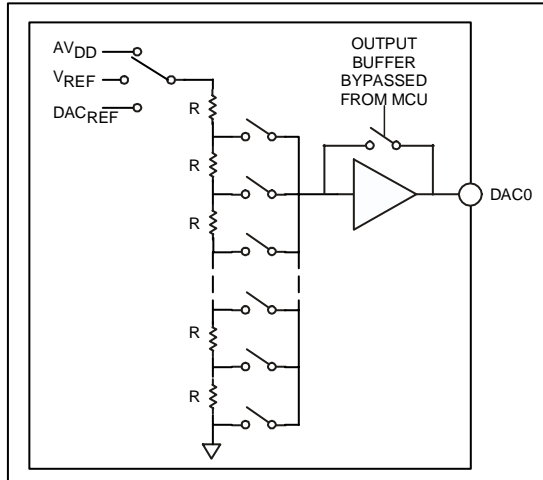

Figure 17: DAC structure

As illustrated in Figure 17, the reference source for each DAC is user selectable in software. It can be either AVDD, VREF or DACREF. In 0-to-AVDD mode, the DAC output transfer function spans from 0 V to the voltage at the AVDD pin. In 0-to-DACREF mode, the DAC output transfer function spans from 0 V to the voltage at the DACREF pin. In 0-to-VREF mode, the DAC output transfer function spans from 0 V to the internal 2.5V reference, VREF. The DAC output buffer amplifier features a true rail-to-rail output stage implementation. This means that, unloaded, each output is capable of swinging to within less than 5 mV of both AVDD and ground. Moreover, the DAC’s linearity specification (when driving a 5k resistive load to ground) is guaranteed through the full transfer function except codes 0 to 100, and, in 0-to-AVDD mode only, codes 3995 to 4095. Linearity degradation near ground and VDD is caused by saturation of the output amplifier, and a general representation of its effects (neglecting offset and gain error) is illustrated in Figure 18. The dotted line in Figure 18 indicates the ideal transfer function, and the solid line represents what the transfer function might look like with endpoint nonlinearities due to saturation of the output amplifier. Note

that Figure 18 represents a transfer function in 0-to-AV_{DD} mode only. In 0-to-V_{REF} or 0-to-DAC_{REF} modes (with V_{REF} < AV_{DD} or DAC_{REF} < AV_{DD}) the lower nonlinearity would be similar, but the upper portion of the transfer function would follow the “ideal” line right to the end (V_{REF} in this case, not AV_{DD}), showing no signs of endpoint linearity errors.

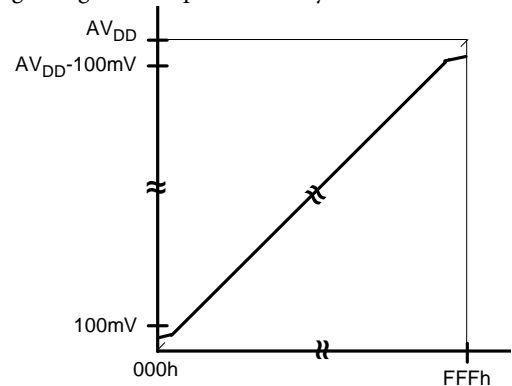

Figure 18: endpoint nonlinearities due to amplifier saturation

The endpoint nonlinearities conceptually illustrated in Figure 18 get worse as a function of output loading. Most of the ADuC702x’s datasheet specifications assume a 5 kΩ resistive load to ground at the DAC output. As the output is forced to source or sink more current, the nonlinear regions at the top or bottom (respectively) of Figure 18 become larger. With larger current demands, this can significantly limit output voltage swing.

To reduce the effects of the saturation of the output amplifier at values close to ground and to give reduced offset and gain errors, the internal buffer can be bypassed in the DAC control register. This allows a full rail-to-rail output from the DAC which should then be buffered externally using a dual supply op-amp in order to get a rail-to-rail output. This external buffer should be located as near as physically possible to the DAC output pin on the PCB.

POWER SUPPLY MONITOR

The Power Supply Monitor monitors the IOV_{DD} supply on the ADuC702x. It indicate when IOV_{DD} supply pin drops below one of two supply trip points. The monitor function is controlled via the PSMCON register. If enabled in the IRQEN or FIQEN register, the monitor will interrupt the core using the PSMI bit in the PSMCON MMR. This bit will be cleared immediately once CMP goes high.

This monitor function allows the user to save working registers to avoid possible data loss due to the low supply or brown-out conditions, and also ensures that normal code execution will not resume until a safe supply level has been established.

Table 21: PSMCON MMR bit descriptions

Bit	Name	Description
3	CMP	Comparator Bit This is a read-only bit and directly reflects the state of the comparator Read '1' indicates the IOV _{DD} supply is above its selected trip point. Read '0' indicates the IOV _{DD} supply is below its selected trip point.
2	TP	Trip Point Selection Bits 0 - 2.79V 1 - 3.07V
1	PSMEN	Power Supply Monitor Enable Bit Set to '1' by the user to enable the Power Supply Monitor circuit Clear to '0' by the user to disable the Power Supply Monitor circuit
0	PSMI	Power Supply Monitor Interrupt Bit. This bit will be set high by the MicroConverter if CMP is low, indicating low I/O supply. The PSMI Bit can be used to interrupt the processor. Once CMP returns high, the PSMI bit may be cleared by writing a '1' to this location. A write of '0' has no effect. There is no timeout delay, PSMI may be cleared immediately once CMP goes high.

COMPARATOR

The ADuC702x also integrates an uncommitted voltage comparator.

The positive input is multiplexed with ADC2 and the negative input has three options: ADC3, DAC0 or a internal 1.08V reference. The output of the comparator can be configured to generate a system interrupt, can be routed directly to the Programmable Logic Array, can start an ADC conversion or be on an external pin, CMP_{OUT}.

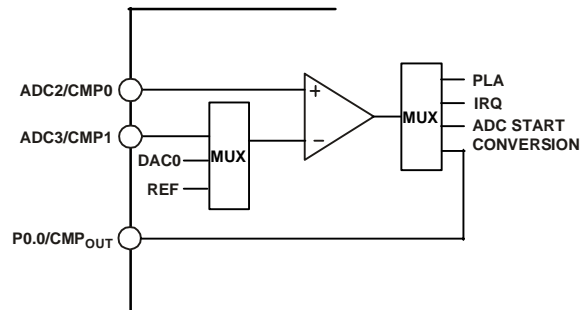

Figure 19: Comparator

The comparator interface consists on a 16-bit MMR, CMPCON described below.

Table 22: CMPCON MMR bit descriptions

Bit	Name	Description
15-11		Reserved
10	CMPEN	Comparator enable bit: Set by user to enable the comparator Cleared by user to disable the comparator
9-8	CMPIN	Comparator negative input select bits: 00 Reference 01 DAC0

7-6	CMPOC	10	ADC3 input
		11	Reserved
		Comparator output configuration bits:	
		00	Start ADC conversion
		01	Output on CMP _{OUT}
5	CMPOL	10	PLA
		11	IRQ
4-3	CMPRES	Comparator output logic state bit	
		When low the comparator output is high when the positive input (CMP0) is above the negative input (CMP1).	
		When high, the comparator output is high when the positive input is below the negative input	
		Response time	
		00	10µs
2	CMPHYST	01	5µs
		10	1µs
		11	0.5µs
		Comparator hysteresis bit:	
1	CMPORI	Set by user to have an hysteresis of about 7.5mV	
		Cleared by user to have no hysteresis	
0	CMPOFI	Comparator output rising edge interrupt	
		Set automatically when a rising edge occurs on the monitored voltage (CMP0)	
0	CMPOFI	Cleared by user by writing a 1 to this bit.	
		Comparator output falling edge interrupt	
0	CMPOFI	Set automatically when a falling edge occurs on the monitored voltage (CMP0)	
		Cleared by user	

OSCILLATOR AND PLL - POWER CONTROL

The ADuC702x integrates a 32.768kHz oscillator, a clock divider and a PLL. The PLL locks onto a multiple (1376) of the internal oscillator to provide a stable 45MHz clock for the system. The core can operate at this frequency, or at binary submultiples of it, to allow power saving. The default core clock is the PLL clock divided by 8 (CD = 3) or 5MHz. The core clock frequency can be output on the ECLK pin as described Figure 20. A power down mode is available on the ADuC702x.

The operating mode, clocking mode and programmable clock divider are controlled via two MMRs, PLLCON and POWCON. PLLCON controls operating mode of the clock system while POWCON controls the core clock frequency and the power-down mode.

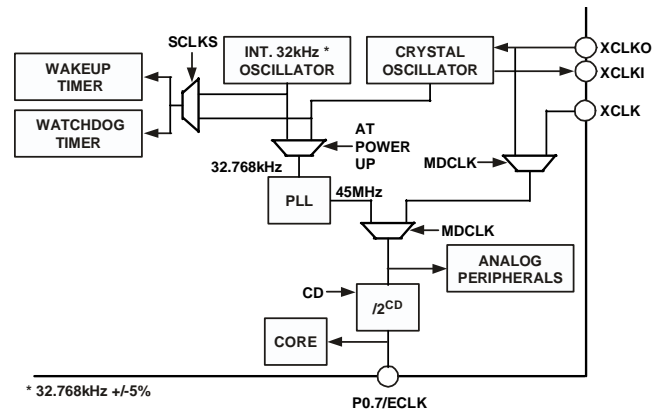

Figure 20: clocking system

A certain sequence has to be followed to write in the PLLCON and POWCON registers, to prevent accidental programming.

PLLCON:	POWCON:
PLLKEY1 = 0xAA	POWKEY1 = 0x01
PLLCON = 0x01	POWCON = 0x00
PLLKEY2 = 0x55	POWKEY1 = 0xF4

Table 23: PLLCON MMR bit designations

Bit	Name	Description
7-3		<i>Reserved</i>
2	SCLKS	Slow clock selection for watchdog timer: <i>Set</i> by the user to use the internal 32kHz for the timer. This bit must be set to use watchdog timer if there is no external crystal <i>Cleared</i> by user to use the external 32kHz crystal
1-0	MDCLK	Clocking modes 00 <i>Reserved</i> 01 PLL + internal 32kHz oscillator – default configuration 10 <i>Reserved</i> 11 XCLK pin

Table 24: POWCON MMR bit designations

Bit	Name	Description
7		<i>Reserved</i>
6-4	PC	Operating modes: 000 Normal mode 011 Power down mode enable. XIRQ0, XIRQ1, timer2 and timer3 can wake-up the ADuC7024/ADuC7025. Others <i>Reserved</i>
3	FINT	Fast interrupt response bit <i>Set</i> by user to enable the fast interrupt response. If an interrupt occurs when FINT is set, the CPU will run at the fastest clock frequency in the interrupt service routine. After completing the ISR, execution resumes at the clock speed set by the CD bits <i>Cleared</i> by user to disable the fast interrupt response
2-0	CD	CPU clock divider bits 000 45.088 MHz 001 22.544 MHz 010 11.272 MHz 011 5.636 MHz 100 2.818 MHz 101 1.409 MHz 110 704.5 kHz 111 352.2 kHz

DIGITAL PERIPHERALS

THREE-PHASE PWM

General overview

The ADuC702x provides a flexible, programmable, three-phase PWM waveform generator that can be programmed to generate the required switching patterns to drive a three-phase voltage source inverter for ac induction (ACIM) motor control.

The PWM generator produces three pairs of PWM signal on the six PWM output pins (PWM0H, PWM0L, PWM1H, PWM1L, PWM2H, and PWM2L). The six PWM output signals consist of three high-side drive signals and three low-side drive signals.

The switching frequency and dead time of the generated PWM patterns are programmable using the PWMDAT0 and PWMDAT1 MMRs. In addition, three duty-cycle control registers (PWMCH0, PWMCH1 and PWMCH2) directly control the duty cycles of the three-pairs of PWM signals.

Each of the six PWM output signals can be enabled or disabled by separate output enable bits of the PWMEN register. In addition, three control bits of the PWMEN register permit crossover of the two signals of a PWM pair. In crossover mode, the PWM signal destined for the high side switch is diverted to the complementary low side output and the signal destined for the low side switch is diverted to the corresponding high side output signal.

In many applications, there is a need to provide an isolation barrier in the gate-drive circuits that turns on the power devices of the inverter. In general, there are two common isolation techniques, optical isolation using opto-couplers and transformer isolation using pulse transformers. The PWM controller permits mixing of the output PWM signals with a high frequency chopping signal to permit easy interface to such pulse transformers. The features of this gate-drive chopping mode can be controlled by the PWMCFG register. An 8-bit value within the PWMCFG register directly controls the chopping frequency. High frequency chopping can be independently enabled for the high-side and the low-side outputs using separate control bits in the PWMCFG register.

The PWM generator is capable of operating in two distinct modes, single update mode or double update mode. In single update mode the duty cycle values are programmable only once per PWM period, so that the resultant PWM patterns are symmetrical about the midpoint of the PWM period. In the double update mode, a second updating of the PWM duty cycle values is implemented at the midpoint of the PWM period. In this mode, it is possible to produce asymmetrical PWM patterns, that produce lower harmonic distortion in three-phase PWM inverters. This technique also permits closed loop

controllers to change the average voltage applied to the machine windings at a faster rate and so permits faster closed loop bandwidths to be achieved. The operating mode of the PWM block is selected by a control bit in the PWMCON register. In single update mode a PWMSYNC pulse is produced at the start of each PWM period. In double update mode, an additional PWMSYNC pulse is produced at the midpoint of each PWM period.

The PWM block can also provide an internal synchronisation pulse on the SYNC pin that is synchronise to the PWM switching frequency. In single update mode a pulse is produced at the start of each PWM period. In double update mode, an additional pulse is also produced at the mid-point of each PWM period. The width of the pulse is programmable through the PWMDAT2 register. The PWM block can also accept an external synchronisation pulse on the SYNC pin. The selection of external synchronisation or internal synchronisation is in the PWMCON register. The SYNC input timing can be synchronised to the internal peripheral clock, which is selected in the PWMCON register. If the external synchronisation pulse from the chip pin is asynchronous to the internal peripheral clock (typical case), the external SYNC is considered asynchronous and should be synchronised. The synchronisation logic will add latency add jitter from the external pulse to the actual PWM outputs. The size of the pulse on the SYNC pin must be greater than two core clock periods.

The PWM signals produced by the ADuC702x can be shut off via a dedicated asynchronous PWM shutdown pin, *PWMTRIP*, that, when brought low, instantaneously places all six PWM outputs in the OFF state (high). This hardware shutdown mechanism is asynchronous so that the associated PWM disable circuitry does not go through any clocked logic, thereby ensuring correct PWM shutdown even in the event of a loss of the core clock.

Status information about the PWM system is available to the user in the PWMSTA register. In particular, the state of the *PWMTRIP* pin is available, as well as a status bit that indicates whether operation is in the first half or the second half of the PWM period.

Description of the PWM block

A functional block diagram of the PWM controller is shown in Figure 21. The generation of the six output PWM signals on pins PWM0H to PWM2L is controlled by four important blocks:

- The Three-Phase PWM Timing Unit, which is the core of the PWM controller. It generates three pairs of complemented and dead-time-adjusted centre-based PWM signals.
- The Output Control Unit allows the redirection of the outputs of the Three-Phase Timing Unit for each channel to either the

high-side or the low-side output. In addition, the Output Control Unit allows individual enabling/disabling of each of the six PWM output signals.

- The Gate Drive Unit permits the generation of the high frequency chopping frequency and its subsequent mixing with the PWM signals.
- The PWM Shutdown Controller takes care of the PWM shutdown via the *PWMTRIP* pin and generates the correct RESET signal for the Timing Unit.

The PWM sync pulse control unit generates the internal synchronisation pulse and also controls whether the external SYNC pin is used or not.

The PWM controller is driven by the ADuC702x core clock frequency and is capable of generating two interrupts to the ARM core. One interrupt is generated on the occurrence of a PWMSYNC pulse and the other is generated on the occurrence of any PWM shutdown action.

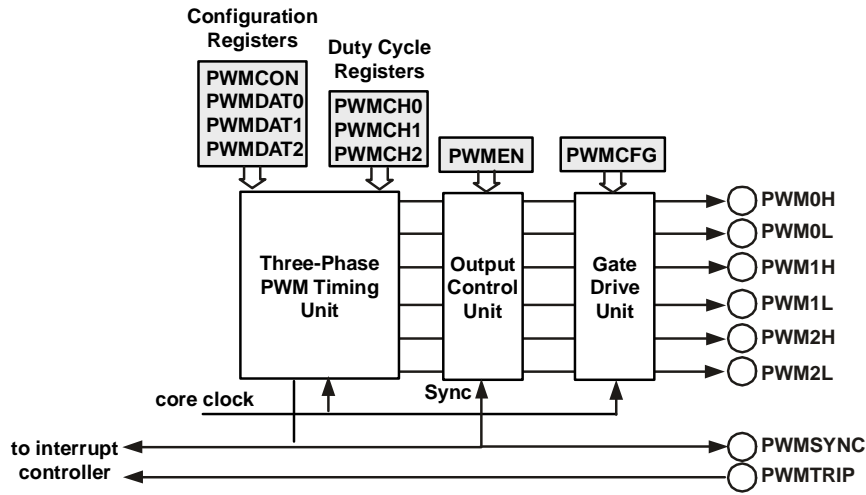

Figure 21: Overview of the PWM controller

Three-phase timing unit

PWM Switching Frequency, PWMDAT0 MMR

The PWM switching frequency is controlled by the PWM period register, PWMDAT0. The fundamental timing unit of the PWM controller is $t_{CORE} = 1/f_{CORE}$ where f_{CORE} is the core frequency of the MicroConverter. Therefore, for a 47 MHz f_{CORE} , the fundamental time increment is 21 ns. The value written to the PWMDAT0 register is effectively the number of t_{CORE} clock increments in half a PWM period. The required PWMDAT0 value is a function of the desired PWM switching frequency (f_{PWM}) and is given by:

$$PWMDAT0 = f_{core} / (2 \times f_{PWM})$$

Therefore, the PWM switching period, T_s , can be written as:

$$T_s = 2 \times PWMDAT0 \times t_{CORE}$$

The largest value that can be written to the 16-bit PWMDAT0 MMR is 0xFFFF = 65535 which corresponds to a minimum PWM switching frequency of:

$$f_{PWM(min)} = 47 \times 10^6 / (2 \times 65535) = 358.59 \text{ Hz}$$

Note that PWMDAT0 value of 0 and 1 are not defined and

should not be used.

PWM Switching Dead Time, PWMDAT1 MMR

The second important parameter that must be set up in the initial configuration of the PWM block is the switching dead time. This is a short delay time introduced between turning off one PWM signal (e.g. AH) and turning on the complementary signal (AL). This short time delay is introduced to permit the power switch being turned off (in this case, AH) to completely recover its blocking capability before the complementary switch is turned on. This time delay prevents a potentially destructive short-circuit condition from developing across the dc link capacitor of a typical voltage source inverter.

The dead time is controlled by the 10-bit, read/write PWMDAT1 register. There is only one dead-time register that controls the dead time inserted into all three pairs of PWM output signals. The dead time, T_D , is related to the value in the PWMDAT1 register by:

$$T_D = PWMDAT1 \times 2 \times t_{CORE}$$

Therefore, a PWMDAT1 value of 0x00A (= 10), introduces an 426 ns delay between the turn-off on any PWM signal (say, AH) and the turn-on of its complementary signal (AL). The amount

of the dead time can therefore be programmed in increments of $2t_{CORE}$ (or 42 ns for a 47 MHz core clock). The PWMDAT1 register is a 10-bit register so that its maximum value is 0x3FF (= 1023), corresponding to a maximum programmed dead time of:

$$TD_{(max)} = 1023 \times 2 \times t_{CORE} = 1023 \times 2 \times 21 \times 10^{-9} = 43.53 \mu s$$

for a core clock of 47 MHz. Obviously, the dead time can be programmed to be zero by writing 0 to the PWMDAT1 register.

PWM Operating Mode, PWMCON and PWMSTA MMRs

The PWM controller of the ADuC702x can operate in two distinct modes, single update mode and double update mode. The operating mode of the PWM controller is determined by the state of Bit 2 of the PWMCON register. If this bit is cleared the PWM operates in the single update mode. Setting Bit 2 places the PWM in the double update mode. The default operating mode is single update mode.

In single update mode, a single PWMSYNC pulse is produced in each PWM period. The rising edge of this signal marks the start of a new PWM cycle and is used to latch new values from the PWM configuration registers (PWMDAT0 and PWMDAT1) and the PWM duty cycle registers (PWMCH0, PWMCH1 and PWMCH2) into the three-phase timing unit. In addition, the PWMEN register is also latched into the output control unit on the rising edge of the PWMSYNC pulse. In effect, this means that the characteristics and resultant duty cycles of the PWM signals can be updated only once per PWM period at the start of each cycle. The result is that PWM patterns that are symmetrical about the midpoint of the switching period are produced.

In double update mode, there is an additional PWMSYNC pulse produced at the midpoint of each PWM period. The rising edge of this new PWMSYNC pulse is again used to latch new values of the PWM configuration registers, duty cycle registers and the PWMEN register. As a result it is possible to alter both the characteristics (switching frequency and dead time) as well as the output duty cycles at the midpoint of each PWM cycle. Consequently, it is possible to produce PWM switching patterns that are no longer symmetrical about the midpoint of the period (asymmetrical PWM patterns). In double update mode, it may be necessary to know whether operation at any point in time is in either the first half or the second half of the PWM cycle. This information is provided by Bit 0 of the PWMSTA register, which is cleared during operation in the first half of each PWM period (between the rising edge of the original PWMSYNC pulse and the rising edge of the new PWMSYNC pulse introduced in double update mode). Bit 0 of the PWMSTA register is set during operation in the second half of each PWM period. This status bit allows the user to make a determination of the particular half-cycle during implementation of the PWMSYNC interrupt service routine, if required.

The advantage of double update mode is that lower harmonic voltages can be produced by the PWM process and faster control bandwidths are possible. However, for a given PWM switching frequency, the PWMSYNC pulses occur at twice the rate in the double update mode. Since new duty cycle values must be computed in each PWMSYNC interrupt service routine, there is a larger computational burden on the ARM core in double update mode.

PWM Duty Cycles, PWMCH0, PWMCH1, PWMCH2 MMRs

The duty cycles of the six PWM output signals on pins AH to CL are controlled by the three 16-bit read/write duty cycle registers, PWMCH0, PWMCH1 and PWMCH2. The duty cycle registers are programmed in integer counts of the fundamental time unit, t_{CORE} , and define the desired on-time of the high-side PWM signal produced by the three-phase timing unit over half the PWM period. The switching signals produced by the three-phase timing unit are also adjusted to incorporate the programmed dead time value in the PWMDAT1 register. The three-phase timing unit produces active low signals so that a low level corresponds to a command to turn on the associated power device.

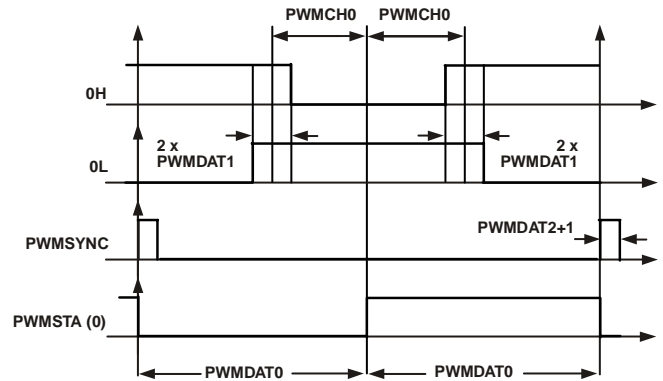

Figure 22: Typical PWM outputs of Three-Phase timing unit in single update mode

A typical pair of PWM outputs (in this case for AH and AL) from the timing unit are shown in Figure 22 for operation in single update mode. All illustrated time values indicate the integer value in the associated register and can be converted to time by simply multiplying by the fundamental time increment, t_{CORE} . First, it is noted that the switching patterns are perfectly symmetrical about the midpoint of the switching period in this single update mode since the same values of PWMCH0, PWMDAT0 and PWMDAT1 are used to define the signals in both half cycles of the period. It can be seen how the programmed duty cycles are adjusted to incorporate the desired dead time into the resultant pair of PWM signals. Clearly, the dead time is incorporated by moving the switching instants of both PWM signals (0H and 0L) away from the instant set by the PWMCH0 register. Both switching edges are moved by an equal amount ($PWMDAT1 \times t_{CORE}$) to preserve the

symmetrical output patterns.

Also shown is the PWMSYNC pulse and Bit 0 of the PWMSTA register that indicates whether operation is in the first or second half cycle of the PWM period.

The resultant on-times of the PWM signals over the full PWM period (two half periods) produced by the timing unit can be written as:

$$T_{OH} = 2 \times (PWMCH0 - PWMDAT1) \times t_{CORE}$$

$$T_{OL} = 2 \times (PWMDAT0 - PWMCH0 - PWMDAT1) \times t_{CORE}$$

And the corresponding duty cycles:

$$d_{OH} = T_{OH} / T_s = (PWMCH0 - PWMDAT1) / PWMDAT0$$

$$d_{OL} = T_{OL} / T_s = (PWMDAT0 - PWMCH0 - PWMDAT1) / PWMDAT0$$

The minimum permissible T_{OH} and T_{OL} values are zero, corresponding to a 0% duty cycle. In a similar fashion, the maximum value is T_s , corresponding to a 100% duty cycle.

The output signals from the timing unit for operation in double update mode are shown in Figure 23. This illustrates a completely general case where the switching frequency, dead time and duty cycle are all changed in the second half of the PWM period. Of course, the same value for any or all of these quantities could be used in both halves of the PWM cycle. However, it can be seen that there is no guarantee that symmetrical PWM signals will be produced by the timing unit in double update mode. Additionally, it is seen that the dead time is inserted into the PWM signals in the same way as in the single update mode.

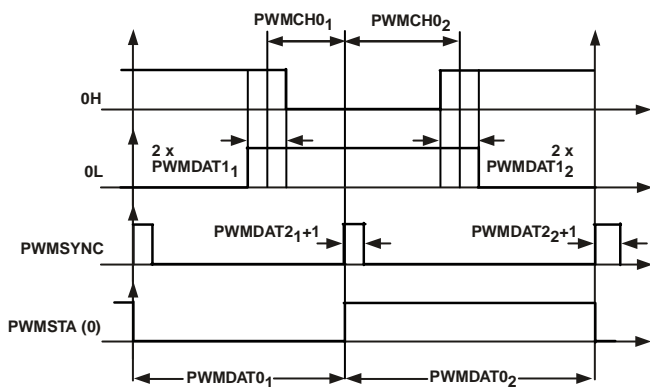

Figure 23: Typical PWM outputs of the Three-phase timing unit in double update mode

In general the on-times of the PWM signals in double update mode can be defined as:

$$T_{OH} = (PWMCH0_1 + PWMCH0_2 - PWMDAT1_1 - PWMDAT1_2) \times t_{CORE}$$

$$T_{OL} = (PWMDAT0_1 + PWMDAT0_2 - PWMCH0_1 - PWMCH0_2 - PWMDAT1_1 - PWMDAT1_2) \times t_{CORE}$$

where the subscript 1 refers to the value of that register during the first half cycle and the subscript 2 refers to the value during the second half cycle. The corresponding duty cycles are:

$$d_{OH} = T_{OH} / T_s = (PWMCH0_1 + PWMCH0_2 - PWMDAT1_1 - PWMDAT1_2) / (PWMDAT0_1 + PWMDAT0_2)$$

$$d_{OL} = T_{OL} / T_s = (PWMDAT0_1 + PWMDAT0_2 - PWMCH0_1 - PWMCH0_2 - PWMDAT1_1 - PWMDAT1_2) / (PWMDAT0_1 + PWMDAT0_2)$$

since for the completely general case in double update mode, the switching period is given by:

$$T_s = (PWMDAT0_1 + PWMDAT0_2) \times t_{CORE}$$

Again, the values of T_{OH} and T_{OL} are constrained to lie between zero and T_s .

PWM signals similar to those illustrated in Figure 22 and Figure 23 can be produced on the 1H, 1L, 2H and 2L outputs by programming the PWMCH1 and PWMCH2 registers in a manner identical to that described for PWMCH0. The PWM controller does not produce any PWM outputs until all of the PWMDAT0, PWMCH0, PWMCH1 and PWMCH2 registers have been written to at least once. Once these registers have been written, internal counting of the timers in the three-phase timing unit is enabled. Writing to the PWMDAT0 register starts the internal timing of the main PWM timer. Provided the PWMDAT0 register is written prior to the PWMCH0, PWMCH1 and PWMCH2 registers in the initialisation, the first PWMSYNC pulse and interrupt (if enabled) appear $1.5 \times t_{CORE} \times PWMDAT0$ seconds after the initial write to the PWMDAT0 register in single update mode. In double update mode, the first PWMSYNC pulse appears after $PWMDAT0 \times t_{CORE}$ seconds.

Output Control Unit

The operation of the Output Control Unit is controlled by the 9-bit read/write PWMEN register. This register controls two distinct features of the Output Control Unit that are directly useful in the control of ECM or BDCM. The PWMEN register contains three crossover bits, one for each pair of PWM outputs. Setting Bit 8 of the PWMEN register enables the crossover mode for the 0H/0L pair of PWM signals, setting Bit 7 enables crossover on the 1H/1L pair of PWM signals and setting Bit 6 enables crossover on the 2H/2L pair of PWM signals. If crossover mode is enabled for any pair of PWM signals, the high-side PWM signal from the timing unit (0H, for example) is diverted to the associated low-side output of the Output Control Unit so that the signal will ultimately appear at the 0L pin. Of course, the corresponding low-side output of the Timing Unit is also diverted to the complementary high-side output of

the Output Control Unit so that the signal appears at the 0H pin. Following a reset, the three crossover bits are cleared so that the crossover mode is disabled on all three pairs of PWM signals. The PWMEN register also contains six bits (Bits 0 to 5) that can be used to individually enable or disable each of the six PWM outputs. If the associated bit of the PWMEN register is set, the corresponding PWM output is disabled irrespective of the value of the corresponding duty cycle register. This PWM output signal will remain in the OFF state as long as the corresponding enable/disable bit of the PWMEN register is set. The implementation of this output enable function is implemented after the crossover function.

Following a reset, all six enable bits of the PWMEN register are cleared so that all PWM outputs are enabled by default. In a manner identical to the duty cycle registers, the PWMEN is latched on the rising edge of the PWMSYNC signal so that changes to this register only become effective at the start of each PWM cycle in single update mode. In double update mode, the PWMEN register can also be updated at the midpoint of the PWM cycle.

In the control of an ECM only two inverter legs are switched at any time and often the high-side device in one leg must be switched ON at the same time as the low-side driver in a second leg. Therefore, by programming identical duty cycles values for two PWM channels (e.g. PWMCH0 = PWMCH1) and setting Bit 7 of the PWMEN register to cross over the 1H/1L pair of PWM signals, it is possible to turn ON the high-side switch of Phase A and the low-side switch of Phase B at the same time. In the control of ECM, it is usual for the third inverter leg (Phase C in this example) to be disabled for a number of PWM cycles. This function is implemented by disabling both the 2H and 2L PWM outputs by setting Bits 0 and 1 of the PWMEN register.

This situation is illustrated in Figure 24, where it can be seen that both the 0H and 1L signals are identical, since PWMCH0 = PWMCH1 and the crossover bit for phase B is set.

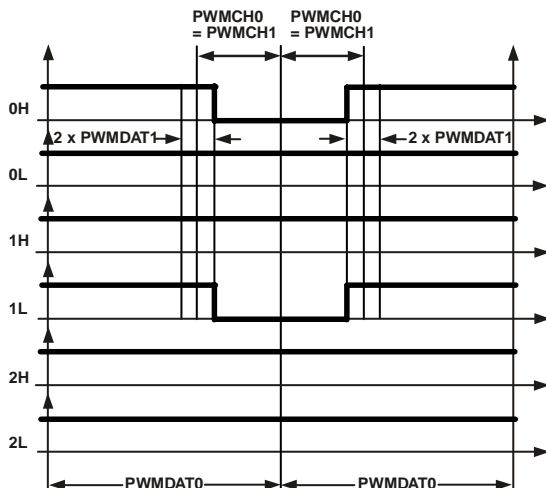

Figure 24. Example active LO PWM signals suitable for ECM control,

PWMCH0 = PWMCH1, crossover BH/BL pair and disable 0L, 1H, 2H and 2L outputs. Operation is in single update mode.

In addition, the other four signals (0L, 1H, 2H and 2L) have been disabled by setting the appropriate enable/disable bits of the PWMEN register. For the situation illustrated in Figure 24, the appropriate value for the PWMEN register is 0x00A7. In normal ECM operation, each inverter leg is disabled for certain periods of time so that the PWMEN register is changed based on the position of the rotor shaft (motor commutation).

Gate Drive Unit

The Gate Drive Unit of the PWM controller adds features that simplify the design of isolated gate drive circuits for PWM inverters. If a transformer-coupled power device gate drive amplifier is used then the active PWM signal must be chopped at a high frequency. The 10-bit read/write PWMCFG register allows the programming of this high frequency chopping mode. The chopped active PWM signals may be required for the high-side drivers only, for the low-side drivers only or for both the high-side and low-side switches. Therefore, independent control of this mode for both high- and low-side switches is included with two separate control bits in the PWMCFG register.

Typical PWM output signals with high frequency chopping enabled on both high-side and low-side signals are shown in Figure 25. Chopping of the high side PWM outputs (0H, 1H and 2H) is enabled by setting Bit 8 of the PWMCFG register. Chopping of the low-side PWM outputs (0L, 1L and 2L) is enabled by setting Bit 9 of the PWMCFG register. The high frequency chopping frequency is controlled by the 8-bit word (GDCLK) placed in Bits 0 to 7 of the PWMCFG register. The period of this high frequency carrier is:

$$T_{chop} = (4 \times (GDCLK + 1)) \times t_{CORE}$$

and the chopping frequency is therefore an integral subdivision of the MicroConverter core frequency:

$$f_{chop} = f_{CORE} / (4 \times (GDCLK + 1))$$

The GDCLK value may range from 0 to 255, corresponding to a programmable chopping frequency rate from 45.9 kHz to 11.75 MHz for a 47 MHz core frequency. The gate drive features must be programmed before operation of the PWM controller and typically are not changed during normal operation of the PWM controller. Following a reset, all bits of the PWMCFG register are cleared so that high frequency chopping is disabled, by default.

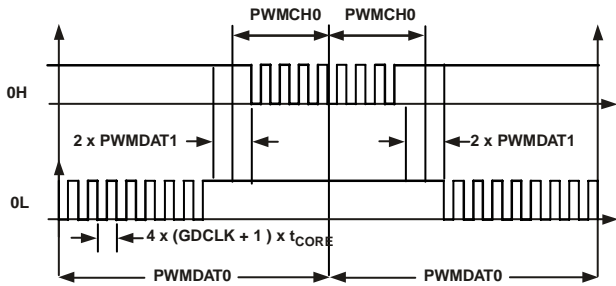

Figure 25: typical PWM signals with high frequency gate chopping enabled on both high-side and low-side switches

PWM shutdown

In the event of external fault conditions, it is essential that the PWM system be instantaneously shut down in a safe fashion. A low level on the *PWMTRIP* pin provides an instantaneous, asynchronous (independent of the MicroConverter core clock) shutdown of the PWM controller. All six PWM outputs are placed in the OFF state, i.e. high state. In addition, the PWMSYNC pulse is disabled. The *PWMTRIP* pin has an internal pull-down resistor so that if the pin becomes disconnected the PWM will be disabled. The state of the *PWMTRIP* pin can be read from Bit 3 of the PWMSTA register.

On the occurrence of a PWM shutdown command, a *PWMTRIP* interrupt will be generated, internal timing of the three-phase timing unit of the PWM controller is stopped.

Following a PWM shutdown, the PWM can only be re-enabled (in a *PWMTRIP* interrupt service routine, for example) by writing to all of the PWMDAT0, PWMCH0, PWMCH1 and PWMCH2 registers. Provided the external fault has been cleared and the *PWMTRIP* has returned to a high level, internal timing of the three-phase timing unit resumes and new duty-cycle values are latched on the next PWMSYNC boundary.

PWM MMRs interface

The PWM block is controlled via the following nine MMRs:

- **PWMCON**: control register, enable the PWM, choose the update rate
- **PWMSTA**: reflects the status of the PWM
- **PWMDAT0**: unsigned 16-bit register for switching period
- **PWMDAT1**: unsigned 10-bit register for dead time
- **PWMCFG**: gate chopping
- **PWMCH0,CH1,CH2**: channel duty cycle for the three phases
- **PWMEN**: allows enabling channel outputs and crossover. See bit definition Table 28.
- **PWMDAT2**: unsigned 10-bit register for PWM sync pulse width.

Table 25: PWMCON MMR Bit Descriptions

Bit	Name	Description
7-5		<i>Reserved</i>
4	PWM_SYNCSEL	External sync select Set to use external sync Cleared to use internal sync
3	PWM_EXTSYNC	External sync select Set to select external synchronous sync signal Cleared for asynchronous sync signal
2	PWMDBL	Double Update Mode Set to '1' by the user to enable double update mode Clear to '0' by the user to enable single update mode
1	PWM_SYNC_EN	PWM synchronisation enable Set by user to enable synchronisation Cleared by user to disable synchronisation
0	PWMEN	PWM Enable Bit Set to '1' by the user to enable the PWM Clear to '0' by the user to disable the PWM. Also cleared automatically with <i>PWMTRIP</i>

Table 26: PWMSTA MMR Bit Descriptions

Bit	Name	Description
15-10		<i>Reserved</i>
9	PWMSYNCINT	PWM sync interrupt bit

8	PWMTRIPINT	PWM trip interrupt bit
3	PWMTRIP	Raw signal from the PWMTRIP pin
2-1		<i>Reserved</i>
0	PWMPHASE	PWM Phase Bit Set to '1' by the MicroConverter when the timer is counting down (1 st half) Clear to '0' by the MicroConverter when the timer is counting up (2 nd half)

Table 27: PWMCFG MMR Bit Descriptions

Bit	Name	Description
9	CHOPLO	low-side Gate Chopping enable bit
8	CHOPHI	high-side Gate Chopping enable bit
0:7	GDCLK	PWM Gate Chopping Period (unsigned)

Table 28: PWMEN MMR bit descriptions

Bit	Name	Description
8	0H0L_XOVR	Channel 0 Output Crossover Enable Bit Set to '1' by the user to enable channel 0 output crossover Clear to '0' by the user to disable channel 0 output crossover
7	1H1L_XOVR	Channel 1 Output Crossover Enable Bit Set to '1' by the user to enable channel 1 output crossover Clear to '0' by the user to disable channel 1 output crossover
6	2H2L_XOVR	Channel 2 Output Crossover Enable Bit Set to '1' by the user to enable channel 2 output crossover Clear to '0' by the user to disable channel 2 output crossover
5	0L_EN	AL Output Enable Bit Set to '1' by the user to disable the 0L output of the PWM Clear to '0' by the user to enable the 0L output of the PWM
4	0H_EN	AH Output Enable Bit Set to '1' by the user to disable the 0H output of the PWM Clear to '0' by the user to enable the 0H output of the PWM
3	1L_EN	BL Output Enable Bit Set to '1' by the user to disable the 1L output of the PWM Clear to '0' by the user to enable the 1L output of the PWM
2	1H_EN	BH Output Enable Bit Set to '1' by the user to disable the 1H output of the PWM Clear to '0' by the user to enable the 1H output of the PWM
1	2L_EN	CL Output Enable Bit Set to '1' by the user to disable the 2L output of the PWM Clear to '0' by the user to enable the 2L output of the PWM
0	2H_EN	CH Output Enable Bit Set to '1' by the user to disable the 2H output of the PWM Clear to '0' by the user to enable the 2H output of the PWM

GENERAL PURPOSE I/O

The ADuC702x provides 40 General Purpose bi-directional I/O pins (GPIO). All I/O pins are 5V tolerant which means that the GPIOs support an input voltage of 5V. In general many of the GPIO pins have multiple functions, see Table 30 for the pin function definition. By default the GPIO pins are configured in GPIO mode. All GPIO pins have internal pull up resistor and their drive capability is 2mA. The drive capability of P0.7 is 12mA.

The 30 GPIO are grouped in 5 ports, port 0 to 4. Each port is controlled by four MMRs:

- **GPxCON:** Port x Control Register, selects the function of each pin of port x. as described in Table 29
 - **GPxDAT:** Port x Configuration and Data Register. It configures the direction of the GPIO pins of port x, sets the output value for the pins configured as output and receives the stores the input value of the pins configured as input.
 - **GPxSET:** data set port x
 - **GPxCLR:** data clear port x
- With x representing the port number.

See Table 6 page 3 for address location of these 20 registers.

The default value of GPxCON is 0x00000000, all port pins are defined as GPIO, except GP0CON which is 0x01001000 in order to make the TRST and MRST functions available at reset.

Table 29: GPxCON MMR Bit Descriptions

Bit	Description
31-30	Reserved
29-28	Select function of Px.7 pin
27-26	Reserved
25-24	Select function of Px.6 pin
23-22	Reserved
21-20	Select function of Px.5 pin
19-18	Reserved
17-16	Select function of Px.4 pin
15-14	Reserved
13-12	Select function of Px.3 pin
11-10	Reserved
9-8	Select function of Px.2 pin
7-6	Reserved
5-4	Select function of Px.1 pin
3-2	Reserved
1-0	Select function of Px.0 pin

Table 30: GPIO pin function Descriptions

Port	Pin	Configuration			
		00	01	10	11
0	P0.0	GPIO	CMP	-	PLAI[7]
	P0.1	GPIO	-	BLE	-
	P0.2	GPIO	-	BHE	-
	P0.3	GPIO	TRST	A16	ADC _{BUSY}
	P0.4	GPIO IRQ0	PWMTRIP	-	PLAO[1]
	P0.5	GPIO IRQ1	ADC _{BUSY}	-	PLAO[2]
	P0.6	GPIO	MRST	AE	PLAO[3]
	P0.7	GPIO	ECLK	SIN	PLAO[4]
1	P1.0	GPIO	SIN	SCL0	PLAI[0]
	P1.1	GPIO	SOUT	SDA0	PLAI[1]
	P1.2	GPIO	RTS	SCL1	PLAI[2]
	P1.3	GPIO	CTS	SDA1	PLAI[3]
	P1.4	GPIO	RI	CLK	PLAI[4]
	P1.5	GPIO	DCD	MISO	PLAI[5]
	P1.6	GPIO	DSR	MOSI	PLAI[6]
	P1.7	GPIO	DTR	CSL	PLAO[0]
2	P2.0	GPIO	CONVS	SOUT	PLAO[5]
	P2.1	GPIO	-	WS	-
	P2.2	GPIO	-	RS	-
	P2.3	GPIO	-	AE	-
	P2.4	GPIO	-	MS0	-
	P2.5	GPIO	-	MS1	-
	P2.7	GPIO	-	MS3	-
3	P3.0	GPIO	PWM0H	AD0	PLAI[8]
	P3.1	GPIO	PWM0L	AD1	PLAI[9]
	P3.2	GPIO	PWM1H	AD2	PLAI[10]
	P3.3	GPIO	PWM1L	AD3	PLAI[11]
	P3.4	GPIO	PWM2H	AD4	PLAI[12]
	P3.5	GPIO	PWM2L	AD5	PLAI[13]
	P3.6	GPIO	PWMTRIP	AD6	PLAI[14]
	P3.7	GPIO	PWMSYNC	AD7	PLAI[15]
4	P4.0	GPIO	-	AD8	PLAO[8]
	P4.1	GPIO	-	AD9	PLAO[9]
	P4.2	GPIO	-	AD10	PLAO[10]
	P4.3	GPIO	-	AD11	PLAO[11]
	P4.4	GPIO	-	AD12	PLAO[12]
	P4.5	GPIO	-	AD13	PLAO[13]
	P4.6	GPIO	-	AD14	PLAO[14]
	P4.7	GPIO	-	AD15	PLAO[15]

Table 31: GPxDAT MMR Bit Descriptions

Bit	Description
31-24	Direction of the data: Set to '1' by the user to configure the GPIO pin as an output Clear to '0' by the user to configure the GPIO pin as an input
23-16	Port x data output
15-8	Reflect the state of Port x pins at reset (read only)
7-0	Port x data input (read only)

Table 32: GPxSET MMR Bit Descriptions

Bit	Description
31-24	<i>Reserved</i>
23-16	Data port x set bit: Set to '1' by the user to set bit on port x. will also set the corresponding bit in the GPxDAT MMR Clear to '0' by the user will not affect the data out
15-0	<i>Reserved</i>

Table 33: GPxCLR MMR Bit Descriptions

Bit	Description
31-24	<i>Reserved</i>
23-16	Data port x clear bit: Set to '1' by the user to clear bit on port x, will also clear the corresponding bit in the GPxDAT MMR Clear to '0' by the user will not affect the data out
15-0	<i>Reserved</i>

SERIAL PORT MUX

The Serial Port Mux multiplexes the serial port peripherals (two I²C, SPI, UART) and the Programmable Logic Array (PLA) to a set of ten GPIO pins. Each pin must be configured to one of its specific I/O function as described in Table 34.

	GPIO	UART	UART/I ² C/SPI	PLA
	00	01	10	11
SPM0	P1.0	SIN	I2C0SCL	PLAI[0]
SPM1	P1.1	SOUT	I2C0SDA	PLAI[1]
SPM2	P1.2	RTS	I2C1SCL	PLAI[2]
SPM3	P1.3	CTS	I2C1SDA	PLAI[3]
SPM4	P1.4	RI	SPICLK	PLAI[4]
SPM5	P1.5	DCD	SPIMISO	PLAI[5]
SPM6	P1.6	DSR	SPIMOSI	PLAI[6]
SPM7	P1.7	DTR	SPICSL	PLAO[0]
SPM8	P0.7	ECLK	SIN	PLAO[4]
SPM9	P2.0	CONV	SOUT	PLAO[5]

Table 34: SPM configuration

Table 34 details the mode for each of the SPMUX GPIO pins. This configuration has to be done via the GP0CON, GP1CON and GP2CON MMRs. By default these ten pins are configured as GPIOs.

UART SERIAL INTERFACE

The UART peripheral is a full-duplex Universal Asynchronous Receiver/Transmitter, fully compatible with the 16450 serial port standard. The UART performs serial-to-parallel conversion on data characters received from a peripheral device or a MODEM, and parallel-to-serial conversion on data characters received from the CPU. The UART includes a fractional divider for baudrate generation and has a network addressable mode. The UART function is made available on the following 10 pins of the ADuC702x:

Pin	Signal	Description
SPM0 (mode 1)	RTS	Request To Send
SPM1 (mode 1)	CTS	Clear To Send
SPM2 (mode 1)	SIN	Serial Receive Data
SPM3 (mode 1)	SOUT	Serial Transmit Data
SPM4 (mode 1)	RI	Ring Indicator
SPM5 (mode 1)	DCD	Data Carrier Detect
SPM6 (mode 1)	DSR	Data Set Ready
SPM7 (mode 1)	DTR	Data Terminal Ready
SPM8 (mode 2)	SIN	Serial Receive Data
SPM9 (mode 2)	SOUT	Serial Transmit Data

Table 35: UART signal description

The serial communication adopts a asynchronous protocol that

supports various word length, stop bits and parity generation options selectable in the configuration register.

Baud rate generation

There is two way of generating the UART baudrate.

- Normal 450 UART baudrate generation:

The baudrate is a divided version of the core clock using the value in COMDIV0 and COMDIV1 MMRs (16-bit value, DL).

$$Baudrate = \frac{45.088MHz}{2^{CD} \times 16 \times 2 \times DL}$$

The following table gives some common baudrate values:

Baudrate	CD	DL	Actual baudrate	% error
9600	0	92h	9651	0.53%
19200	0	49h	19301	0.53%
115200	0	0Ch	117417	1.92%
9600	3	12h	9785	1.92%
19200	3	9h	19569	1.92%
115200	3	1h	88062	23.55%

Table 36: baudrate using the normal baudrate generator

- Using the fractional divider:

The fractional divider combined with the normal baudrate generator allows the generating of a wider range of more accurate baudrates.

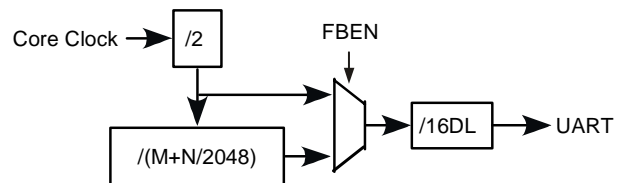

Figure 26: baudrate generation options

Calculation of the baudrate using fractional divider is as follow:

$$Baudrate = \frac{45.088MHz}{2^{CD} \times 16 \times DL \times 2 \times (M + \frac{N}{2048})}$$

$$M + \frac{N}{2048} = \frac{45.088MHz}{Baudrate \times 2^{CD} \times 16 \times DL \times 2}$$

Example:

Generation of 9600 baud with CD bits = 3. The previous table gives DL = 12h.

$$M + \frac{N}{2048} = \frac{45.088MHz}{9600 \times 2^3 \times 16 \times 18 \times 2}$$

$$M + \frac{N}{2048} = 1.019$$

M = 1 and N = 0.019 x 2048 = 39

$$Baudrate = \frac{45.088MHz}{2^3 \times 16 \times 18 \times 2 \times (1 + \frac{39}{2048})}$$

Baudrate = 9602 bps

Error = 0.02% compared to 1.92% with the normal baudrate generator.

UART registers definition

The UART interface consists on 12 registers namely:

- **COMTX:** 8-bit transmit register
- **COMRX:** 8-bit receive register
- **COMDIV0:** divisor latch (low byte)
COMTX, COMRX and COMDIV0 share the same address location. COMTX and COMRX can be accessed when bit 7 in COMCON0 register is cleared. COMDIV0 can be accessed when bit 7 of COMCON0 is set.
- **COMDIV1:** divisor latch (high byte)
- **COMCON0:** line control register
- **COMSTA0:** line status register
- **COMIEN0:** interrupt enable register
- **COMIID0:** interrupt identification register
- **COMCON1:** modem control register
- **COMSTA1:** modem status register
- **COMDIV2:** 16-bit fractional baud divide register
- **COMSCR:** 8-bit scratch register used for temporary storage.
Also used in network addressable UART mode.

Table 37: COMCON0 MMR Bit Descriptions

Bit	Name	Description
7	DLAB	Divisor latch access Set by user to enable access to COMDIV0 and COMDIV1 registers Cleared by user to disable access to COMDIV0 and COMDIV1 and enable access to COMRX and COMTX
6	BRK	Set break. Set by user to force SOUT to 0 Cleared to operate in normal mode
5	SP	Stick parity Set by user to force parity to defined values: 1 if EPS = 1 and PEN = 1 0 if EPS = 0 and PEN = 1
4	EPS	Even parity select bit Set for even parity Cleared for odd parity
3	PEN	Parity enable bit: Set by user to transmit and check the parity bit Cleared by user for no parity transmission or checking
2	STOP	Stop bit Set by user to transmit 1.5 Stop bit if the Word Length is 5 bits or 2 Stop bits if the word length is 6, 7 or 8 bits. The receiver checks the first Stop bit only, regardless of the number of Stop bits selected Cleared by user to generate 1 Stop bit in the transmitted data
1-0	WLS	Word length select: 00 = 5 bits 01 = 6 bits 10 = 7 bits 11 = 8 bits

Table 38: COMSTA0 MMR Bit Descriptions

Bit	Name	Description
7		<i>Reserved</i>
6	TEMT	COMTX empty status bit Set automatically if COMTX is empty Cleared automatically when writing to COMTX
5	THRE	COMTX and COMRX empty Set automatically if COMTX and COMRX are empty Cleared automatically when one of the register receives data
4	BI	Break error Set when SIN is held low for more than the maximum word length Cleared automatically
3	FE	Framing error Set when invalid stop bit Cleared automatically
2	PE	Parity error Set when a parity error occurs Cleared automatically
1	OE	Overrun error Set automatically if data are overwrite before been read Cleared automatically
0	DR	Data ready Set automatically when COMRX is full Cleared by reading COMRX

Table 39: COMIEN0 MMR Bit Descriptions

Bit	Name	Description
7-4		<i>Reserved</i>
3	EDSSI	Modem status interrupt enable bit Set by user to enable generation of an interrupt if any of COMSTA1[3:0] are set Cleared by user
2	ELSI	RX status interrupt enable bit Set by user to enable generation of an interrupt if any of COMSTA0[3:0] are set Cleared by user
1	ETBEI	Enable transmit buffer empty interrupt Set by user to enable interrupt when buffer is empty during a transmission Cleared by user
0	ERBFI	Enable receive buffer full interrupt Set by user to enable interrupt when buffer is full during a reception Cleared by user

Table 40: COMIID0 MMR Bit Descriptions

Bit 2-1 Status bits	Bit 0 NINT	Priority	Definition	Clearing operation
00	1		No interrupt	
11	0	1	Receive line status interrupt	Read COMSTA0
10	0	2	Receive buffer full interrupt	Read COMRX
01	0	3	Transmit buffer empty interrupt	Write data to COMTX or read COMIID0
00	0	4	Modem status interrupt	Read COMSTA1 register

Table 41: COMCON1 MMR Bit Descriptions

Bit	Name	Description
7-5		<i>Reserved</i>
4	LOOPBACK	Loop back Set by user to enable loop back mode. In loop back mode the SOUT is forced high. Also the modem signals are directly connected to the status inputs (RTS to CTS, DTR to DSR, OUT1 to RI and OUT2 to DCD)
1	RTS	Request to send Set by user to force the RTS output to 0 Cleared by user to force the RTS output to 1
0	DTR	Data terminal ready Set by user to force the DTR output to 0 Cleared by user to force the DTR output to 1

Table 42: COMSTA1 MMR Bit Descriptions

Bit	Name	Description
7	DCD	Data carrier detect
6	RI	Ring indicator
5	DSR	Data set ready
4	CTS	Clear to send
3	DDCD	Delta DCD Set automatically if DCD changed state since COMSTA1 last read Cleared automatically by reading COMSTA1
2	TERI	Trailing edge RI Set if NRI changed from 0 to 1 since COMSTA1 last read Cleared automatically by reading COMSTA1
1	DDSR	Delta DSR Set automatically if DSR changed state since COMSTA1 last read Cleared automatically by reading COMSTA1
0	DCTS	Delta CTS Set automatically if CTS changed state since COMSTA1 last read Cleared automatically by reading COMSTA1

Table 43: COMDIV2 MMR Bit Descriptions

Bit	Name	Description
15	FBEN	Fractional baudrate generator enable bit Set by user to enable the fractional baudrate generator Cleared by user to generate baudrate using the standard 450 UART baudrate generator
14-13		<i>Reserved</i>
12-11	FBM[1-0]	M. if FBM = 0, M = 4
10-0	FBN[10-0]	N

Network addressable UART mode

This mode allows connecting the MicroConverter on a 256-node serial network, either as a hardware single-master or via software in a multi-master network. Bit 7 of COMIEN1 (ENAM bit) must be set to enable UART in network addressable mode.

Note that there is no parity check in this mode, the parity bit is used for address.

Network addressable UART register definitions

Three additional register:

- **COMSCR:** 8-bit scratch register used for temporary storage. In network address mode, the least significant bit of the

scratch register is the transmitted network address control bit. If set to 1, the device is transmitting an address. If cleared to 0, the device is transmitting data.

- **COMIEN1:** 8-bit network enable register.
- **COMIID1:** 8-bit network interrupt register. Bit 7 to 4 are reserved. See Table 45.
- **COMADR:** 8-bit read and write network address register. Holds the address the network addressable UART checks for. On receiving this address the device interrupts the processor and/or sets the appropriate status bit in COMIID1. COMIEN1, COMIID1 and COMADR are used only in network addressable UART mode.

Table 44: COMIEN1 MMR Bit Descriptions

Bit	Name	Description
7	ENAM	Network address mode Enable bit set by user to enable network address mode cleared by user to disable network address mode
6	E9BT	9-bit transmit enable bit Set by user to enable 9-bit transmit. ENAM must be set Cleared by user to disable 9-bit transmit
5	E9BR	9-bit receive enable bit Set by user to enable 9-bit receive. ENAM must be set Cleared by user to disable 9-bit receive
4	ENI	network interrupt Enable bit
3	E9BD	Word length Set for 9-bit data. E9BT has to be cleared. Cleared for 8-bit data
2	ETD	Transmitter pin driver Enable bit Set by user to enable SOUT pin as an output in slave mode or multi-master mode Cleared by user, SOUT is three-state
1	NABP	Network address bit, interrupt polarity bit
0	NAB	Network address bit Set by user to transmit the slave's address Cleared by user to transmit data

Table 45: COMIID1 MMR Bit Descriptions

Bit 3-1 Status bits	Bit 0 NINT	priority	Definition	Clearing operation
000	1		No interrupt	
110	0	2	Matching network address	Read COMRX
101	0	3	Address transmitted, buffer empty	Write data to COMTX or read COMIID0
011	0	1	Receive line status interrupt	Read COMSTA0
010	0	2	Receive buffer full interrupt	Read COMRX
001	0	3	Transmit buffer empty interrupt	Write data to COMTX or read COMIID0
000	0	4	Modem status interrupt	Read COMSTA1 register

SERIAL PERIPHERAL INTERFACE

The ADuC702x integrates a complete hardware Serial Peripheral Interface (SPI) on-chip. SPI is an industry standard synchronous serial interface that allows eight bits of data to be synchronously transmitted and received simultaneously, i.e., full duplex up to a maximum bit rate of 5.6Mbs. The SPI Port can be configured for Master or Slave operation and typically consists of four pins, namely:

MISO (Master In, Slave Out Data I/O Pin)

The MISO (master in slave out) pin is configured as an input line in master mode and an output line in slave mode. The MISO line on the master (data in) should be connected to the MISO line in the slave device (data out). The data is transferred as byte wide (8-bit) serial data, MSB first.

MOSI (Master Out, Slave In Pin)

The MOSI (master out slave in) pin is configured as an output line in master mode and an input line in slave mode. The MOSI line on the master (data out) should be connected to the MOSI line in the slave device (data in). The data is transferred as byte wide (8-bit) serial data, MSB first.

SCL (Serial Clock I/O Pin)

The master serial clock (SCL) is used to synchronize the data being transmitted and received through the MOSI SCL period. Therefore, a byte is transmitted/received after eight SCL periods. The SCL pin is configured as an output in master mode and as an input in slave mode.

In master mode polarity and phase of the clock are controlled by the SPICON register, and the bit-rate is defined in the

SPIDIV register as follow:

$$f_{serialclock} = \frac{f_{coreclock}}{2 \times (1 + SPIDIV)}$$

The maximum serial bit clock frequency is 1/8 of the core clock which, based on a maximum core clock frequency of 45MHz is just above 5.6Mbs.

In slave mode the SPICON register must be configured with the phase and polarity of the expected input clock.

In both master and slave modes, the data is transmitted on one edge of the SCL signal and sampled on the other. It is important therefore that the polarity and phase are configured the same for the master and slave devices.

Chip Select (CS) Input Pin

In SPI Slave Mode, a transfer is initiated by the assertion of F V# which is an active low input signal. The SPI port will then transmit and receive 8-bit data until the transfer is concluded by desassertion of F V. In slave mode F V is always an input.

SPI registers definition

The following MMR registers are used to control the SPI interface:

- **SPICON:** 16-bit control register
- **SPISTA:** 8-bit read only status register
- **SPIDIV:** 8-bit serial clock divider register
- **SPITX:** 8-bit write only transmit register
- **SPIRX:** 8-bit read only receive register

Table 46: SPICON MMR Bit Descriptions

Bit	Description
15-13	Reserved
12	Continuous transfer enable Set by user to enable continuous transfer. In master mode the transfer will continue until no valid data is available in the TX register. CS will be asserted and remain asserted for the duration of each 8-bit serial transfer until TX is empty Cleared by user to disable continuous transfer. Each transfer consists of a single 8-bit serial transfer. If valid data exists in the SPITX register then a new transfer is initiated after a stall period
11	Loop back enable Set by user to connect MISO to MOSI and test software Cleared by user to be in normal mode
10	Slave output enable Set by user to enable the slave output Cleared by user to disable slave output
9	Slave select input enable Set by user in master mode to enable the output
8	SPIRX overflow overwrite enable Set by user, the valid data in the RX register is overwritten by the new serial byte received

7	<p><i>Cleared</i> by user, the new serial byte received is discarded</p> <p>SPITX underflow mode</p> <p><i>Set</i> by user to transmit the previous data</p>
6	<p><i>Cleared</i> by user to transmit 0</p> <p>Transfer and interrupt mode (master mode)</p> <p><i>Set</i> by user to initiate transfer with a write to the SPITX register. Interrupt will occur when TX is empty</p> <p><i>Cleared</i> by user to initiate transfer with a read of the COMRX register. Interrupt will occur when RX is full</p>
5	<p>LSB first transfer enable bit</p> <p><i>Set</i> by user the LSB is transmitted first</p> <p><i>Cleared</i> by user the MSB is transmitted first</p>
4	<p><i>Reserved</i></p>
3	<p>Serial clock polarity mode bit</p> <p><i>Set</i> by user, the serial clock idles high</p> <p><i>Cleared</i> by user the serial clock idles low</p>
2	<p>Serial clock phase mode bit</p> <p><i>Set</i> by user, the serial clock pulses at the beginning of each serial bit transfer</p> <p><i>Cleared</i> by user, the serial clock pulses eat end of each serial bit transfer</p>
1	<p>Master mode enable bit</p> <p><i>Set</i> by user to enable master mode</p> <p><i>Cleared</i> by user to enable slave mode</p>
0	<p>SPI enable bit</p> <p><i>Set</i> by user to enable the SPI</p> <p><i>Cleared</i> to disable the SPI</p>

Table 47: SPISTA MMR Bit Descriptions

Bit	Description
7-6	<i>Reserved</i>
5	<p>SPIRX data register overflow status bit</p> <p><i>Set</i> if SPIRX is overflowing</p> <p><i>Cleared</i> by reading SPISRX register</p>
4	<p>SPIRX data register IRQ</p> <p><i>Set</i> automatically if bit 3 or 5 are set</p> <p><i>Cleared</i> by reading SPIRX register</p>
3	<p>SPIRX data register full status bit</p> <p><i>Set</i> automatically if a valid data is present in the SPIRX register</p> <p><i>Cleared</i> by reading SPIRX register</p>
2	<p>SPITX data register underflow status bit</p> <p><i>Set</i> automatically if SPITX is under flowing</p> <p><i>Cleared</i> by writing in the SPITX register</p>
1	<p>SPITX data register IRQ</p> <p><i>Set</i> automatically if bit 0 or bit 2 are set</p> <p><i>Cleared</i> by writing in the SPITX register</p>
0	<p>SPITX data register empty status bit</p> <p><i>Set</i> automatically if SPITX is empty</p> <p><i>Cleared</i> by writing to SPITX</p>

I²C COMPATIBLE INTERFACES

The ADuC702x supports two fully licensed I²C interfaces. The I²C interfaces are both implemented as a full hardware master and slave interface. The two I²C interfaces being identical, this document will describe only I²C0 in detail.

The two pins used for data transfer, SDA and SCL are configured in a Wired-AND format that allows arbitration in a multi-master system.

The I²C bus peripheral's addresses in the I²C bus system is programmed by the user. This ID can be modified at any time while a transfer is not in progress. The user can configure the interface to respond to four slave addresses.

The transfer sequence of a I²C system consists of a master device initiating a transfer by generating a START condition while the bus is idle. The master transmits the address of the slave device and the direction of the data transfer in the initial address transfer. If the master does not loose arbitration and the slave acknowledges then the data transfer is initiated. This continues until the master issues a STOP condition and the bus becomes idle.

The I²C peripheral master and slave functionality are independent and may be active simultaneously.

A slave is activated when a transfer has been initiated on the bus. If it is not being addressed it will remain inactive until another transfer is initiated. This also allows a master device which loses arbitration to respond as a slave in the same cycle.

Serial Clock Generation

The I²C master in the system generates the serial clock for a transfer. The master channel can be configured to operate in Fast mode (400 kHz) or Standard mode (100 kHz).

The bit-rate is defined in the I2C0DIVH and I2C0DIVL MMRs as follow:

$$f_{serialclock} = \frac{f_{coreclock}}{2 \times (2 + I2C0DIVH + I2C0DIVL)}$$

Slave addresses

The registers I2C0ID0, I2C0ID1, I2C0ID2 and I2C0ID3 contain the device IDs. The device compares the four I2C0IDx registers to the address byte. The 7 most significant bits of either ID register must be identical to that of the 7 most significant bits of the first address byte received to be correctly addressed. The LSB of the ID registers, transfer direction bit, is ignored in the process of address recognition.

I²C registers description

The I²C peripheral interface consists on 17 8-bit MMRs:

- **I2C0CFG**: configuration register described Table 48
- **I2C0DIVH, I2C0DIVL**: clock divider registers
- **I2C0SRX, I2C0STX, and I2C0SSTA**: respectively receive, transmit and status register for the slave channel. The status register is described Table 49.
- **I2C0ID0, I2C0ID1, I2C0ID2 and I2C0ID3**: slave address device ID register
- **I2C0MRX, I2C0MTX, and I2C0MSTA**: respectively receive, transmit and status register for the master channel. The status register is described Table 50.
- **I2C0CNT**: Master receive data count register. If a master read transfer sequence is initiated, the I2C0CNT register denotes the number of bytes to be read from the slave device.
- **I2C0ADR**: master address byte register. The I2C0ADR value is the address of the device the master wants to communicate with, it will be transmitted automatically at the start of a master transfer sequence if there is no valid data in the I2C0MTX register when setting the master enable bit.
- **I2C0ALT**: hardware general call ID register, used in slave mode

Table 48: I2C0CFG MMR Bit Descriptions

Bit	Description
7	Master serial clock enable bit <i>Set</i> by user to enable generation of the serial clock in master mode <i>Cleared</i> by user to disable serial clock in master mode
6	Loop back enable bit <i>Set</i> by user to internally connect the transition to the reception, to test user software <i>Cleared</i> by user to operate in normal mode
5	START back-off disable bit <i>Set</i> by user in multi-master mode. If losing arbitration the master will try to transmit again straight away <i>Cleared</i> by user to enable START back-off. The master after losing arbitration will wait before trying to transmit again
4	Hardware general call enable (bit 3 must be set) <i>Set</i> by user to enable hardware general call <i>Cleared</i> by user to disable hardware general call

3	<p>General call enable bit</p> <p><i>Set</i> by user to address every device on the I²C bus</p> <p><i>Cleared</i> by user to operate in normal mode</p>
2	<i>Reserved</i>
1	<p>Master enable bit</p> <p><i>Set</i> by user to enable the master I²C channel</p> <p><i>Cleared</i> by user to disable the master I²C channel</p>
0	<p>Slave enable bit</p> <p><i>Set</i> by user to enable the slave I²C channel. A slave transfer sequence will be monitored for the device address in I2C0ID0, I2C0ID1, I2C0ID2 and I2C0ID3. if the device address is recognised the part will participate in the slave transfer sequence</p> <p><i>Cleared</i> by user to disable the slave I²C channel</p>

Table 49: I2C0SSTA MMR Bit Descriptions

Bit	Description
7	<p>Transmit FIFO flush</p> <p><i>Set</i> by user to flush the transmit FIFO</p> <p><i>Cleared</i> by user to operate in normal mode</p>
6	<p>Slave busy</p> <p><i>Set</i> automatically if the slave is busy</p> <p><i>Cleared</i> automatically</p>
5	<p>No ACK</p> <p><i>Set</i> if master asking for data and no data is available</p> <p><i>Cleared</i> automatically</p>
4	<p>Slave receive FIFO overflow</p> <p><i>Set</i> automatically if the slave receive FIFO is overflowing</p> <p><i>Cleared</i> automatically by reading I2C0SRX</p>
3	<p>Slave receive IRQ</p> <p><i>Set</i> after receiving data</p> <p><i>Cleared</i> automatically by reading the I2C0SRX register</p>
2	<p>Slave transmit IRQ</p> <p><i>Set</i> at the end of a transmission</p> <p><i>Cleared</i> automatically by writing to the I2C0STX register</p>
1	<p>Slave transmit FIFO underflow</p> <p><i>Set</i> automatically if the slave transmit FIFO is underflowing</p> <p><i>Cleared</i> automatically by writing to the I2C0STX register</p>
0	<p>Slave transmit FIFO empty</p> <p><i>Set</i> automatically if the slave transmit FIFO is empty</p> <p><i>Cleared</i> automatically by writing to the I2C0STX register</p>

Table 50: I2C0MSTA MMR Bit Descriptions

Bit	Description
7	<p>Transmit FIFO flush</p> <p><i>Set</i> by user to flush the transmit FIFO</p> <p><i>Cleared</i> by user to operate in normal mode</p>
6	<p>Master busy</p> <p><i>Set</i> automatically if the master is busy</p> <p><i>Cleared</i> automatically</p>
5	<p>Arbitration loss</p> <p><i>Set</i> in multi-master mode if another master has the bus</p> <p><i>Cleared</i> when the bus becomes available</p>

4	No ACK <i>Set</i> automatically, if the master receive FIFO is full, the master doesn't acknowledge the data received <i>Cleared</i> automatically
3	Master receive FIFO overflow <i>Set</i> automatically if the master receive FIFO is overflowing <i>Cleared</i> automatically by reading I2C0MRX
2	Master receive IRQ <i>Set</i> after receiving data <i>Cleared</i> automatically by reading the I2C0MRX register
1	Master transmit IRQ <i>Set</i> at the end of a transmission <i>Cleared</i> automatically by writing to the I2C0MTX register
0	Master TX FIFO empty <i>Set</i> automatically if the master transmit FIFO is empty <i>Cleared</i> automatically by writing to the I2C0MTX register

* Purchase of licensed I²C components of Analog Devices or one of its sublicensed Associated Companies conveys a license for the purchaser under the Philips I²C Patent Rights to use the ADuC702X in an I²C system, provided that the system conforms to the I²C Standard Specification as defined by Philips.

PROGRAMMABLE LOGIC ARRAY (PLA)

The ADuC702x integrates a fully Programmable Logic Array (PLA) which consists of two independent but interconnected PLA blocks. Each block consists of eight PLA elements, which gives a total of 16 PLA elements.

A PLA element contains a two-input lookup table that can be configured to generate any logic output function based on two inputs and a flip-flop as represented in Figure 27 below.

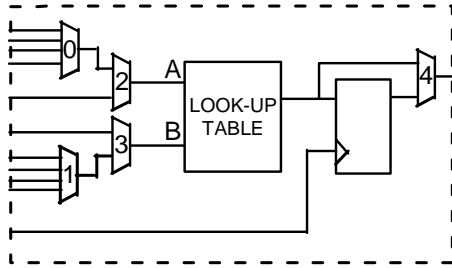

Figure 27: PLA element

In total, 30 GPIO pins are available on the ADuC702x for the PLA. These include 16 input pins and 14 output pins. They need to be configured in the GPxCON register as PLA pins before using the PLA. Note that the comparator output is also included as one of the 16 input pins.

The PLA is configured via a set of user MMRs and the output(s) of the PLA can be routed to the internal interrupt system, to the CONV_{START} signal of the ADC, to a MMR or to any of the 16 PLA output pins.

The interconnection between the two block is supported by connecting output of element 7 of block 1 fed back to the input 0 of mux 0 of element 0 of block 0, and the output of element 7 of block 0 is fed back to the input 0 of mux 0 of element 0 of block 1.

PLA Block 0			PLA Block 1		
Element	Input	Output	Element	Input	Output
0	P1.0	P1.7	8	P3.0	P4.0
1	P1.1	P0.4	9	P3.1	P4.1
2	P1.2	P0.5	10	P3.2	P4.2
3	P1.3	P0.6	11	P3.3	P4.3
4	P1.4	P0.7	12	P3.4	P4.4
5	P1.5	P2.0	13	P3.5	P4.5
6	P1.6	-	14	P3.6	P4.6
7	P0.0	-	15	P3.7	P4.7

Table 51: element input/output

PLA MMRs interface

The PLA peripheral interface consists on 21 MMRs:

- **PLAELMx**: element0 to element 15 control registers, configure the input and output mux of each element, select the function in the lookup table and enable/disable the flip-flop.
- **PLACLK**: clock selection for the flip-flops of block 0 and clock selection for the flip-flops of block 1
- **PLAIRQ**: enable IRQ0 or/and IRQ1 and select the source of the IRQ
- **PLAADC**: PLA source fro ADC start conversion signal
- **PLADIN**: data input MMR for PLA
- **PLADOUT**: data output MMR for PLA. This register is always updated.

A PLA tool is provided in the development system to easily configure the PLA.

Table 52: PLAELMx MMR Bit Descriptions

Bit	Description	PLAELM0	PLAELM1 - 7	PLAELM8	PLAELM9-15
31-11	Reserved				
10-9	Mux (0) control, select feedback from:	00 – element 15 01 – element 2 10 – element 4 11 – element 6	element 0 element 2 element 4 element 6	element 7 element 10 element 12 element 14	element 8 element 10 element 12 element 14
8-7	Mux (1) control, select feedback from:	00 – element 1 01 – element 3 10 – element 5 11 – element 7	element 1 element 3 element 5 element 7	element 9 element 11 element 13 element 15	element 9 element 11 element 13 element 15
6	Mux (2) control Set by user to select the output of mux (1) Cleared by user to select the bit value from PLADIN				
5	Mux (3) control Set by user to select the input pin of the particular element Cleared by user to select the output of mux (0) Look-up table control 0000 – 0				

4-1	Look-up table control	0000 – 0 0001 – NOR 0010 – A AND NOT B 0011 – NOT A 0100 – NOT A AND B 0101 – NOT B 0110 – EXOR 0111 – NAND 1000 – AND 1001 – EXNOR 1010 – B 1011 – NOT A OR B 1100 – A 1101 – A OR NOT B 1110 – OR 1111 – 1
0	Mux (4) control	Set by user to bypass the flip-flop Cleared by user to select the flip-flop. Cleared by default

Table 53: PLACLK MMR Bit Descriptions

Bit	Description
7	<i>Reserved</i>
6-4	Block1 clock source selection: 000 – GPIO clock on P0.5 001 – GPIO clock on P0.0 010 – GPIO clock on P0.7 011 – HCLK 100 – OCLK 101 - Timer 1 Other – <i>Reserved</i>
3	<i>Reserved</i>
2-0	Block0 clock source selection: 000 – GPIO clock on P0.5 001 – GPIO clock on P0.0 010 – GPIO clock on P0.7 011 – HCLK 100 – OCLK 101 - Timer 1 Other – <i>Reserved</i>

Table 54: PLAIRQ MMR Bit Descriptions

Bit	Description
15-13	<i>Reserved</i>
12	PLA IRQ1 enable bit Set by user to enable IRQ1 output from PLA Cleared by user to disable IRQ1 output from PLA
11-8	PLA IRQ1 source 0000 – PLA element 0 0001 – PLA element 1 ... 1111 – PLA element 15
7-5	<i>Reserved</i>

4	PLA IRQ0 enable bit Set by user to enable IRQ0 output from PLA Cleared by user to disable IRQ0 output from PLA
3-0	PLA IRQ0 source 0000 – PLA element 0 0001 – PLA element 1 ... 1111 – PLA element 15

Table 55: PLAADC MMR Bit Descriptions

Bit	Description
31-5	Reserved
4	ADC start conversion enable bit Set by user to enable ADC start conversion from PLA Cleared by user to disable ADC start conversion from PLA
3-0	ADC start conversion source 0000 – PLA element 0 0001 – PLA element 1 ... 1111 – PLA element 15

Table 56: PLADIN MMR Bit Descriptions

Bit	Description
31-16	Reserved
15-0	Input Bit from element 15-0

Table 57: PLADOUT MMR Bit Descriptions

Bit	Description
31-16	Reserved
15-0	Output Bit from element 15-0

PROCESSOR REFERENCE PERIPHERALS

INTERRUPT SYSTEM

There are 24 interrupt sources on the ADuC702x which are controlled by the Interrupt Controller. Most interrupts are generated from the on-chip peripherals like ADC, UART, etc. and two additional interrupt sources are generated from external interrupt request pins, XIRQ0 and XIRQ1. The ARM7TDMI CPU core will only recognise interrupts as one of two types, a normal interrupt request IRQ and a fast interrupt request FIQ. All the interrupts can be masked separately.

The control and configuration of the interrupt system is managed through nine interrupt-related registers, four dedicated to IRQ, four dedicated to FIQ. An additional MMR is used to select the programmed interrupt source. The bits in each IRQ and FIQ registers represent the same interrupt source as described in Table 58.

Table 58: IRQ/FIQ MMRs bit description

Bit	Description
0	All interrupts OR'ed
1	SWI: not used in IRQEN/CLR and FIQEN/CLR
2	Timer 0
3	Timer 1
4	Wake Up timer – Timer 2
5	Watchdog timer – Timer 3
6	Flash control
7	ADC channel
8	PLL lock
9	I ² C0 Slave
10	I ² C0 Master
11	I ² C1 Master
12	SPI Slave
13	SPI Master
14	UART
15	External IRQ0
16	Comparator
17	PSM
18	External IRQ1
19	PLA IRQ0
20	PLA IRQ1
21	IO onto SPM4
22	IO onto SPM5
23	PWM trip
24	PWM sync

IRQ

The IRQ is the exception signal to enter the IRQ mode of the processor. It is used to service general purpose interrupt handling of internal and external events.

The four 32-bit registers dedicated to IRQ are:

- **IRQSIG**, reflects the status of the different IRQ sources. If a peripheral generate an IRQ signal, the corresponding bit in the IRQSIG will be set, otherwise it is cleared. The IRQSIG bits are cleared when the interrupt in the particular peripheral is cleared. All IRQ sources can be masked in the IRQEN MMR. IRQSIG is read-only.
- **IRQEN**, provides the value of the current enable mask. When bit is set to 1, the source request is enabled to create an IRQ exception. When bit is set to 0, the source request is disabled or masked which will not create an IRQ exception.
- **IRQCLR**, (write-only register) allows clearing the IRQEN register in order to mask an interrupt source. Each bit set to 1 will clear the corresponding bit in the IRQEN register without affecting the remaining bits. The pair of registers IRQEN and IRQCLR allows independent manipulation of the enable mask without requiring an atomic read-modify-write.
- **IRQSTA**, (read-only register) provides the current enabled IRQ source status. When set to 1 that source should generate an active IRQ request to the ARM7TDMI core. There is no priority encoder or interrupt vector generation. This function is implemented in software in a common interrupt handler routine. All 32 bits are logically OR'ed to create the IRQ signal to the ARM7TDMI core.

FIQ

The FIQ (Fast Interrupt reQuest) is the exception signal to enter the FIQ mode of the processor. It is provided to service data transferor communication channel tasks with low latency. The FIQ interface is identical to the IRQ interface providing the second level interrupt (highest priority). Four 32-bit registers are dedicated to FIQ, FIQSIG, FIQEN, FIQCLR and FIQSTA.

Bit 31 to 1 of FIQSTA are logically OR'ed to create the FIQ signal to the core and the bit 0 of both the FIQ and IRQ registers (FIQ source).

The logic for FIQEN and FIQCLR will not allow an interrupt source to be enabled in both IRQ and FIQ masks. A bit set to '1' in FIQEN will, as a side-effect, clear the same bit in IRQEN. A bit set to '1' in IRQEN will, as a side-effect, clear the same bit in FIQEN. An interrupt source can be disabled in both IRQEN and FIQEN masks.

Programmed interrupts

As the programmed interrupts are non-mask-able, they are controlled by another register, SWICFG, which write into both IRQSTA and IRQSIG registers or/and FIQSTA and FIQSIG

registers at the same time.

programmed source interrupt.

The 32-bit register dedicated to software interrupt is SWICFG described Table 59. This MMR allows the control of

Table 59: SWICFG MMR Bit Descriptions

Bit	Description
31-3	<i>Reserved</i>
2	Programmed Interrupt-FIQ Setting/clearing this bit correspond in setting/clearing bit 1 of FIQSTA and FIQSIG
1	Programmed Interrupt-IRQ Setting/clearing this bit correspond in setting/clearing bit 1 of IRQSTA and IRQSIG
0	<i>Reserved</i>

Note that any interrupt signal must be active for at least the equivalent of the interrupt latency time, to be detected by the interrupt controller and to be detected by user in the IRQSTA/FIQSTA register.

TIMERS

The ADuC702x has four general purpose Timer/Counters:

- Timer0,
- Timer1,
- Timer2 or Wake-up Timer,
- Timer3 or Watchdog Timer.

The four timers in their normal mode of operation can be either free-running or periodic.

- In free-running mode the counter decrements/increments from the maximum/minimum value until zero/full scale and starts again at the maximum /minimum value.
- In periodic mode the counter decrements/increments from the value in the Load Register(TxLD MMR,) until zero/full scale and starts again at the value stored in the Load Register.

The value of a counter can be read at any time by accessing its value register (TxVAL). Timers are started by writing in the Control register of the corresponding timer (TxCON).

In normal mode, an IRQ is generated each time the value of the counter reaches zero, if counting down, or full-scale, if counting up. An IRQ can be cleared by writing any value to Clear register of the particular timer (TxCLRI).

Timer0 – RTOS timer

Timer0 is a general purpose 16-bit count-down timer with a programmable prescaler. The prescaler source is the core clock frequency and can be scaled by factors of 1, 16 or 256.

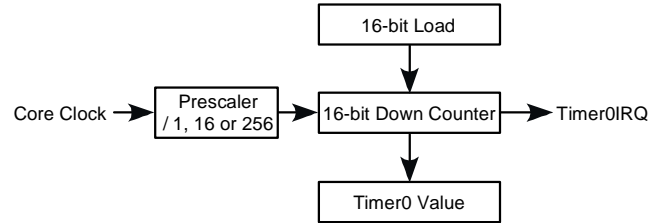

Figure 28:timer 0 block diagram

Timer0 interface consists in four MMRS:

- **T0LD** and **T0VAL** are 16-bit registers (bit 0 to 15) and hold 16-bit unsigned integers. T0VAL is read-only.
- **T0CLRI** is an 8-bit register. Writing any value to this register will clear the interrupt
- **T0CON** is the configuration MMR described in Table 60 below

Table 60: T0CON MMR Bit Descriptions

Bit	Name	Description
31-8		Reserved
7		Timer0 enable bit: Set by user to enable timer 0 Cleared by user to disable timer 0. by default.
6		Timer 0 mode: Set by user to operate in periodic mode Cleared by user to operate in free-running mode. Default mode
5-4		Reserved
3-2		Prescale: 00 Core clock / 1. value by default 01 Core clock / 16 10 Core clock / 256 11 Undefined. Equivalent to 00
1-0		Reserved

Timer1

Timer1 is a 32-bit general purpose timer, count-down or count-up, with a programmable prescaler. The prescaler source can be the 32kHz Oscillator, the core clock frequency, or an external GPIO, P1.0 or P0.6. This source can be scaled by a factor of 1, 16, 256 or 32768.

The counter can be formatted as a standard 32-bit value or as Hours:Minutes:Seconds:Hundreths.

Timer1 has a capture register (T1CAP), which can be triggered by a selected IRQ source initial assertion. This feature can be used to determine the assertion of an event with more accuracy than the precision allowed by the RTOS timer at the time the IRQ is serviced.

Timer 1 can be used to start ADC conversions as shown in the block diagramFigure 29.

Timer1 interface consists in five MMRS:

- **T1LD**, **T1VAL** and **T1CAP** are 32-bit registers and hold 32-

bit unsigned integers. T1VAL and T1CAP are read-only.
 - **T1CLR1** is an 8-bit register. Writing any value to this register will clear the timer1 interrupt.

- **T1CON** is the configuration MMR described in Table 61 below.

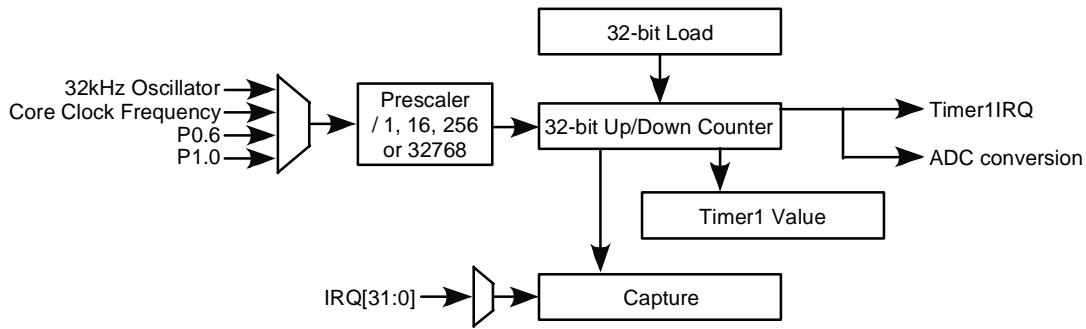

Figure 29:timer 1 block diagram

Table 61: T1CON MMR Bit Descriptions

Bit	Description
31-18	Reserved
17	Event Select bit: Set by user to enable time capture of an event Cleared by user to disable time capture of an event
16-12	Event select range, 0 to 31 The events are as described in Table 58. All events are offset by 2, i.e. event 2 in Table 58 becomes event zero for the purposes of timer 1.
11-9	Clock select: 000 Core clock 001 Oscillator 32.768kHz 010 P1.0 raising edge triggered 011 P0.6 raising edge triggered
8	Count up: Set by user for timer 1 to count up Cleared by user for timer 1 to count down. by default
7	Timer1 enable bit: Set by user to enable timer 1 Cleared by user to disable timer 1. by default.
6	Timer 1 mode: Set by user to operate in periodic mode Cleared by user to operate in free-running mode. Default mode
5-4	Format: 00 Binary 01 Reserved 10 Hr:Min:Sec:Hundredths – 23 hours to 0 hour 11 Hr:Min:Sec:Hundredths – 255 hours to 0 hour
3-0	Prescale: 0000 Source clock / 1 0100 Source clock / 16 1000 Source clock / 256 1111 Source clock / 32768

Timer2 - Wake-Up Timer

Timer2 is a 32-bit wake-up timer, count-down or count-up, with a programmable prescaler. It is clocked directly by the

internal 32.768kHz oscillator. The wake-up timer will continue to run when the core clock is disabled. The clock source can be scaled by a factor of 1, 16, 256 or 32768.

The counter can be formatted as plain 32-bit value or as Hours:Minutes:Seconds:Hundredths.

Timer 2 can be used to start ADC conversions as shown in the block diagram Figure 30..

Timer2 interface consists in four MMRS:

- **T2LD** and **T2VAL** are 32-bit registers and hold 32-bit unsigned integers. T2VAL is read-only.
- **T2CLRI** is an 8-bit register. Writing any value to this register will clear the timer2 interrupt.
- **T2CON** is the configuration MMR described in Table 62 below.

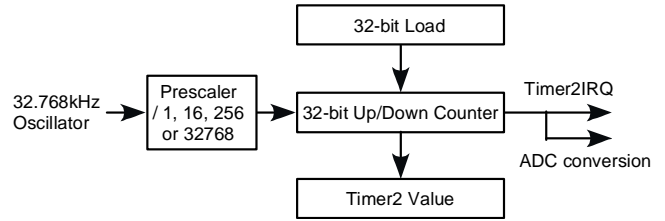

Figure 30:timer 2 block diagram

Table 62: T2CON MMR Bit Descriptions

Bit	Description
31-9	Reserved
8	Count up: Set by user for timer 2 to count up Cleared by user for timer 2 to count down. by default
7	Timer2 enable bit: Set by user to enable timer 2 Cleared by user to disable timer 2. by default.
6	Timer 2 mode: Set by user to operate in periodic mode Cleared by user to operate in free-running mode. Default mode
5-4	Format:
	00 Binary
	01 Reserved
	10 Hr:Min:Sec:Hundredths – 23 hours to 0 hour
	11 Hr:Min:Sec:Hundredths – 255 hours to 0 hour
3-0	Prescale:
	0000 Source clock / 1 by default
	0100 Source clock / 16
	1000 Source clock / 256 expected for format 2 and 3
	1111 Source clock / 32768

Timer3 - Watchdog Timer

Timer3 has two modes of operation, normal mode and watchdog mode. The Watchdog timer is used to recover from an illegal software state. Once enabled it requires periodic servicing to prevent it from forcing a reset of the processor.

Normal mode:

The Timer3 in normal mode is identical to Timer0 except for the clock source and the count-up functionality. The clock source is 32kHz from the PLL and can be scaled by a factor of 1, 16 or 256.

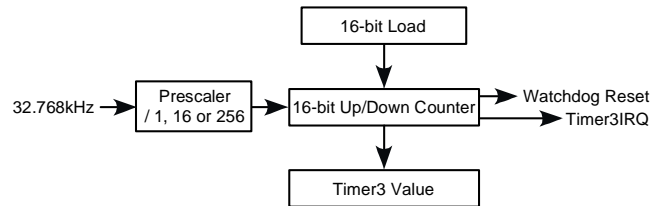

Figure 31:timer 3 block diagram

Watchdog mode:

Watchdog mode is entered by setting bit 5 in T3CON MMR. Timer3 decrements from the value present in T3LD Register until zero. T3LD is used as timeout. The timeout can be 512 seconds maximum, using the maximum prescaler, /256, full-scale in T3LD. Timer3 is clocked by the internal 32kHz crystal when operating in the Watchdog mode.

If the timer reaches 0, a reset or an interrupt occurs, depending on bit 1 in T3CON register. To avoid reset or interrupt, any

value must be written to T3ICLR before the expiration period. This reloads the counter with T3LD and begins a new timeout period.

As soon watchdog mode is entered, T3LD and T3CON are write-protected. These two registers can not be modified until a reset clears the watchdog enable bit and causes Timer3 to exit watchdog mode.

Timer3 interface:

It consists in four MMRS:

- **T3LD** and **T3VAL** are 16-bit registers (bit 0 to 15) and hold 16-bit unsigned integers. T0VAL is read-only.
- **T3CLRI** is an 8-bit register. Writing any value to this register will clear the timer3 interrupt in normal mode or will reset a new timeout period in watchdog mode.
- **T3CON** is the configuration MMR described in Table 63.

Secure bit clear (watchdog mode only):

The secure clear bit is provided for a higher level of protection. When set, a specific sequential value must be written to T3ICLR to avoid a watchdog reset. The value is a sequence generated by the 8-bit LFSR (Linear Feedback Shift Register) polynomial = $X^8 + X^6 + X^5 + X + 1$ as shown Figure 32. The

initial value or seed is written to T3ICLR before entering watchdog mode. After entering watchdog mode, a write to T3ICLR must match this expected value. If it matches, the LFSR is advanced to the next state when the counter reload happens. If it fails to match the expected state, reset is immediately generated, even if the count has not yet expired. The value 0x00 should not be used as an initial seed due to the properties of the polynomial. The value 0x00 will always be guaranteed to force an immediate reset. The value of the LFSR can not be read; it must be tracked/generated in software.

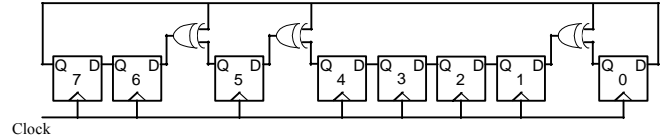

Figure 32: 8-bit LFSR

Example of sequence:

- 1) entered initial seed in T3ICLR, 0xAA, before starting timer 3 in watchdog mode
- 2) enter 0xAA in T3ICLR, timer 3 is reloaded
- 3) enter 0x37 in T3ICLR, timer 3 is reloaded
- 4) enter 0x6E in T3ICLR, timer 3 is reloaded
- 5) enter 0x66. 0xDC was expected, the watchdog reset the chip.

Table 63: T3CON MMR Bit Descriptions

Bit	Description
31-9	Reserved
8	Count up: Set by user for timer 2 to count up Cleared by user for timer 2 to count down. by default
7	Timer2 enable bit: Set by user to enable timer 2 Cleared by user to disable timer 2. by default.
6	Timer 2 mode: Set by user to operate in periodic mode Cleared by user to operate in free-running mode. Default mode
5	Watchdog mode enable bit: Set by user to enable watchdog mode Cleared by user to disable watchdog mode. by default.
4	Secure Clear bit: Set by user to use the secure clear option Cleared by user to disable the secure clear option. by default.
3-2	Prescale: 00 Source clock / 1 by default 01 Source clock / 16 10 Source clock / 256 11 Undefined. Equivalent to 00
1	Watchdog IRQ option bit: Set by user to produce an IRQ instead of a reset when the watchdog reaches 0 Cleared by user to disable the IRQ option.
0	Reserved

External Memory Interfacing

The only ADuC702x models which feature an external memory interface are the ADuC7026 and ADuC7027. The external memory interface requires a larger number of pins, this is why it is only available on larger pin count package.

The pins required for interfacing to an external memory are:

Pin	Function
AD[15:0}	Address/Data Bus
A16	Extended Addressing
MS[3:0}	Memory Select Pins
WR	Write Strobe
RS	Read Strobe
AE	Address Latch Enable
BHE, BLE	Byte Write Capability

There are four external memory regions available. These are

XMxCON

Bit	Description
1	Selects between 8 and 16 bit data bus width. Set by the user to select a 16 bit data bus Cleared by the user to select an 8 bit data bus.
0	Enables Memory Region Set by the user to enable memory region Cleared by the user to disable the memory region

XMxPAR

Bit	Description
15	Enable Byte write strobe Set by the user gates the BHE and BLE outputs with the WR output. This allows byte write capability without using
14-12	Number of wait states on the Address latch enable strobe.
11	Enable dynamic addressing Set by the user to enable 16 bit addressing mode Cleared by the user to enable 8 bit addressing mode
10	Extra address hold time Set by the user to disable extra hold time Cleared by the user to enable one clock cycle of hold on address in read and write
9	Extra bus transition time on Read Set by the user to disable extra bus transition time

documented in the table below.

Address Start	Address End	Contents
0x10000000	0x1001FFFF	External Memory 0
0x20000000	0x2001FFFF	External Memory 1
0x30000000	0x3001FFFF	External Memory 2
0x40000000	0x4001FFFF	External Memory 3

Each external memory region can be controlled through the following three MMRs

XMCFG is set to 1 to enable external memory access. This must be set to 1 before any port pins will function as external memory access pins. The port pins must also be individually enabled via the **GPxCON** MMR

XMxCON are registers that enable/disable a memory region. This register also controls the data bus width of the memory region.

XMxPAR are registers that define the protocol used for accessing the external memory for each memory region.

	Cleared by the user to enable one extra clock before and after the Read Strobe, RS
8	Extra bus transition time on Write Set by the user to disable extra bus transition time
	Cleared by the user to enable one extra clock before and after the Write Strobe, WS
7-4	Number of Write Wait States Set by the user to select the number of wait states added to the length of the WS pulse. 0x0 is 1clock 0xF is 16 clock cycles (default value)
3-0	Number of Read Wait States Set by the user to select the number of wait states added to the length of the RS pulse. 0x0 is 1clock 0xF is 16 clock cycles (default value)

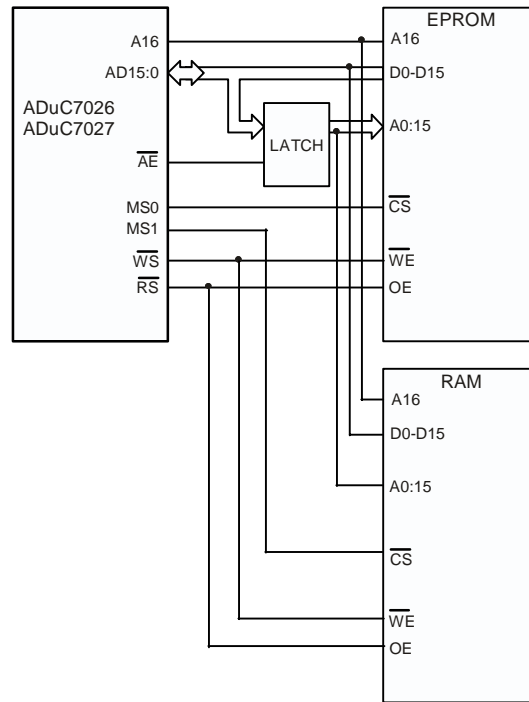

Figure 33 Interfacing to external EPROM/RAM



Figure 34: External Memory Read Cycle

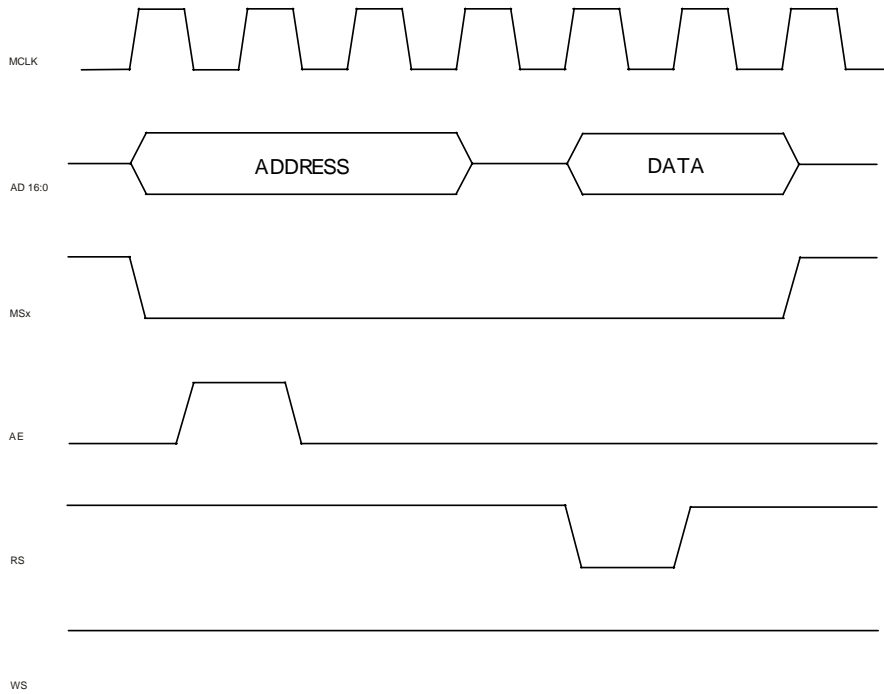

Figure 35: External Memory Read cycle with Address hold and Bus turn cycles

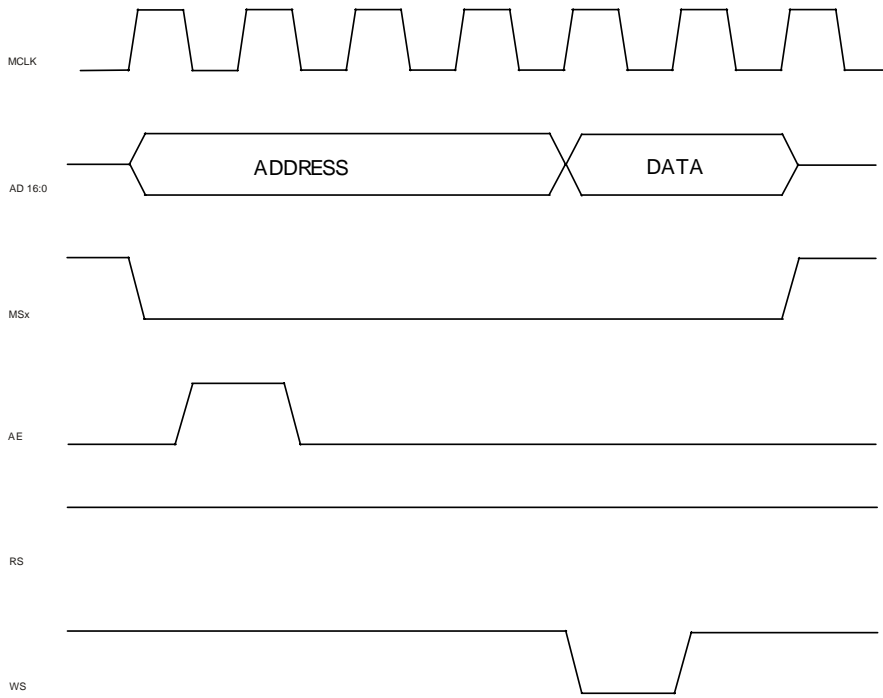

Figure 36: External Memory Write Cycle with address and write hold cycles

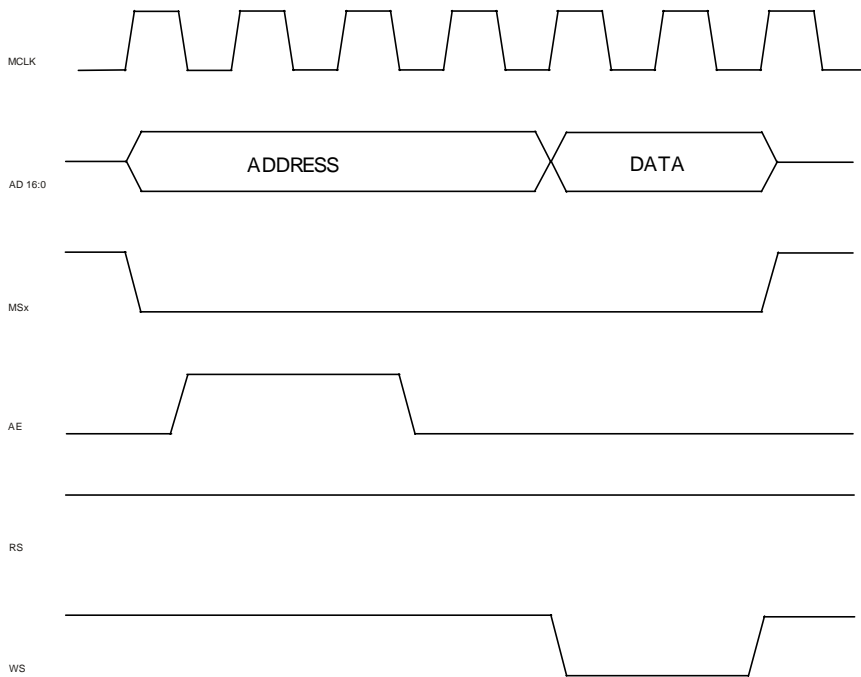

Figure 37: External Memory Write Cycle with wait states

ADUC702X HARDWARE DESIGN CONSIDERATIONS

POWER SUPPLIES

The ADuC702X operational power supply voltage range is 2.7V to 3.6V. Separate analog and digital power supply pins (AV_{DD} and IOV_{DD} , respectively) allow AV_{DD} to be kept relatively free of noisy digital signals often present on the system IOV_{DD} line. In this mode, the part can also operate with split supplies; that is, using different voltage supply levels for each supply. For example, this means that the system can be designed to operate with a IOV_{DD} voltage level of 3.3 V while the AV_{DD} level can be at 3 V, or vice versa if required. A typical split supply configuration is shown in Figure 38.

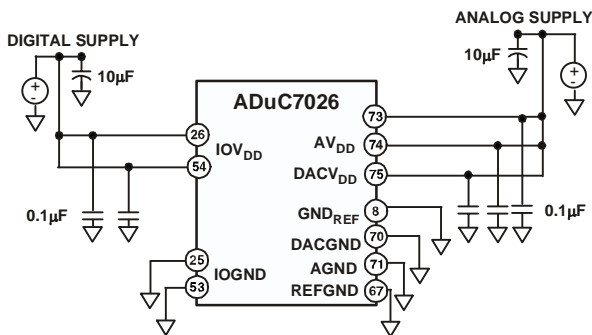

Figure 38: External dual supply connections

As an alternative to providing two separate power supplies, the user can help keep AV_{DD} quiet by placing a small series resistor and/or ferrite bead between it and IOV_{DD} , and then decoupling AV_{DD} separately to ground. An example of this configuration is shown in Figure 39. With this configuration other analog circuitry (such as op amps, voltage reference, and so on) can be powered from the AV_{DD} supply line as well.

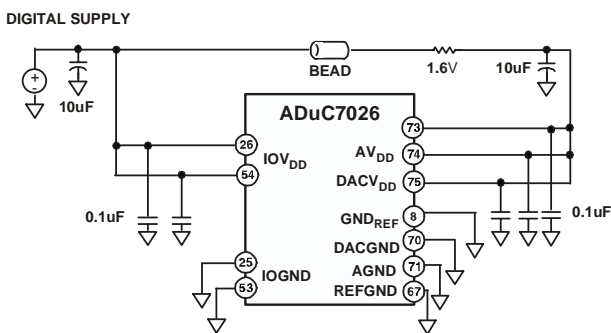

Figure 39: external single supply connections

Notice that in both Figure 38 and Figure 39, a large value (10 μ F) reservoir capacitor sits on IOV_{DD} and a separate 10 μ F capacitor sits on AV_{DD} . Also, local small-value (0.1 μ F) capacitors are located at each AV_{DD} and IOV_{DD} pin of the chip. As per standard design practice, be sure to include all of these capacitors, and ensure the smaller capacitors are close to each

AV_{DD} pin with trace lengths as short as possible. Connect the ground terminal of each of these capacitors directly to the underlying ground plane. Finally, it should also be noted that, at all times, the analog and digital ground pins on the ADuC702x must be referenced to the same system ground reference point.

Linear Voltage regulator

The ADuC702x requires a single 3.3V supply but the core logic requires a 2.5V supply. An on-chip linear regulator generates the 2.5V from IOV_{DD} for the core logic. LV_{DD} pin 21 is the 2.5V supply for the core logic. An external compensation capacitor of 0.47 μ F must be connected between LV_{DD} and DGND (as close as possible to these pins) to act as a tank of charge as shown Figure 40.

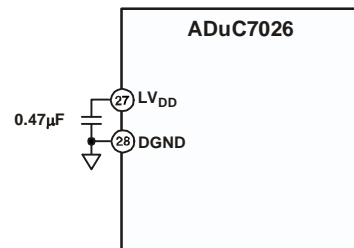

Figure 40: voltage regulator connections

The LV_{DD} pin should not be used for any other chip. It is also recommended that the IOV_{DD} has excellent power supply decoupling this to help improving line regulation performance of the on-chip voltage regulator.

GROUNDING AND BOARD LAYOUT RECOMMENDATIONS

As with all high resolution data converters, special attention must be paid to grounding and PC board layout of ADuC702x-based designs in order to achieve optimum performance from the ADCs and DAC.

Although the ADuC702x has separate pins for analog and digital ground (AGND and IOGND), the user must not tie these to two separate ground planes unless the two ground planes are connected together very close to the ADuC702x, as illustrated in the simplified example of Figure 41a. In systems where digital and analog ground planes are connected together somewhere else (at the system's power supply for example), they cannot be connected again near the ADuC702x since a ground loop would result. In these cases, tie the ADuC702x's AGND and IOGND Pins all to the analog ground plane, as illustrated in Figure 41b. In systems with only one ground plane, ensure that the digital and analog components are physically separated onto separate halves of the board such that digital return currents do not flow near analog circuitry and vice versa. The ADuC702x can then be placed between the

digital and analog sections, as illustrated in Figure 41c.

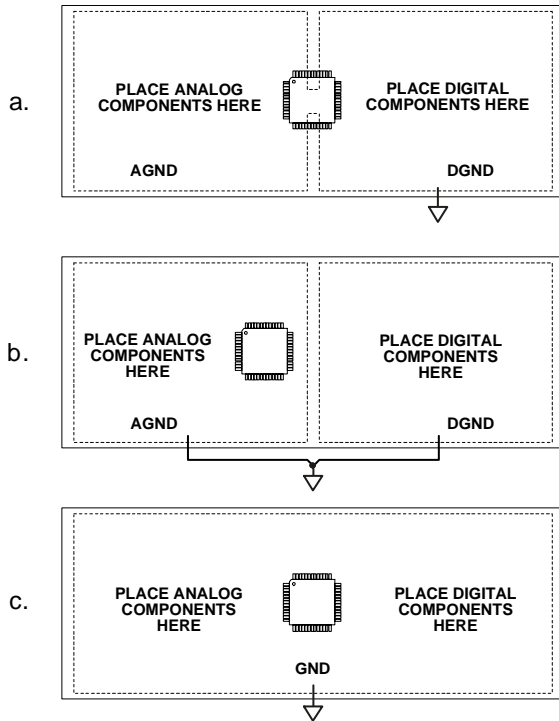

Figure 41: System grounding schemes

In all of these scenarios, and in more complicated real-life applications, keep in mind the flow of current from the supplies and back to ground. Make sure the return paths for all currents are as close as possible to the paths the currents took to reach their destinations. For example, do not power components on the analog side of Figure 41b with IOV_{DD} since that would force return currents from IOV_{DD} to flow through AGND. Also, try to avoid digital currents flowing under analog circuitry, which could happen if the user placed a noisy digital chip on the left half of the board in Figure 41c. Whenever possible, avoid large discontinuities in the ground plane(s) (such as are formed by a long trace on the same layer), since they force return signals to travel a longer path. And of course, make all connections to the ground plane directly, with little or no trace separating the pin from its via to ground.

If the user plans to connect fast logic signals (rise/fall time < 5 ns) to any of the ADuC702x's digital inputs, add a series resistor to each relevant line to keep rise and fall times longer than 5 ns at the ADuC702x input pins. A value of 100Ω or 200Ω is usually sufficient to prevent high speed signals from coupling capacitively into the ADuC702x and affecting the accuracy of ADC conversions.

CLOCK OSCILLATOR

The clock source for the ADuC702x can be generated by the internal PLL or by an external clock input. To use the internal PLL, connect a 32.768kHz parallel resonant crystal between

XCLKI and XCLKO and connect a capacitor from each pin to ground as shown Figure 42. This crystal allows the PLL to lock correctly to give a frequency of 45.088MHz. If no external crystal is present, the internal oscillator will be used to give a frequency of 45.088MHz ±5% typically.

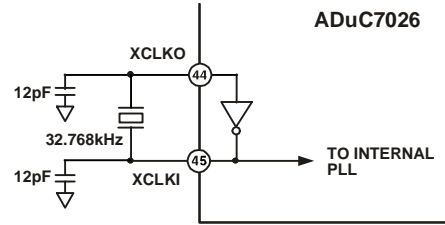

Figure 42: external parallel resonant crystal connections

To use an external source clock input instead of the PLL, bit 1 and bit 0 of PLLCON must be modified. The external clock uses pin 17, XCLK.

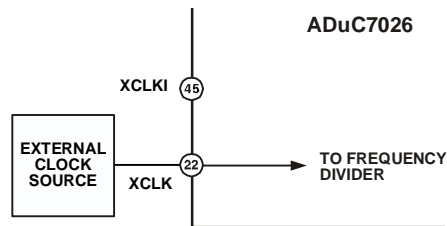

Figure 43: connecting an external clock source

Whether using the internal PLL or an external clock source, the ADuC702x's specified operational clock speed range is 50kHz to 20MHz to ensure correct operation of the analog peripherals and Flash/EE.

POWER-ON RESET OPERATION

An internal POR (Power-On Reset) is implemented on the ADuC702x. For LV_{DD} below 1.98 V, the internal POR will hold the ADuC702x in reset. As LV_{DD} rises above 1.98 V, an internal timer will time out for typically 128 ms before the part is released from reset. The user must ensure that the power supply IOV_{DD} has reached a stable 2.7 V minimum level by this time. Likewise on power-down, the internal POR will hold the ADuC702x in reset until LV_{DD} has dropped below 1.98V. Figure 44 illustrates the operation of the internal POR in detail.

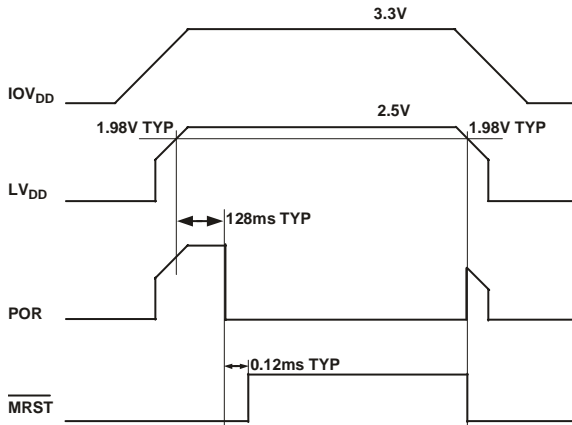

Figure 44: ADuC7024/ADuC7025 Internal Power-on-Reset operation

TYPICAL SYSEM CONFIGURATION

A typical ADuC7024/ADuC7025 configuration is shown in Figure 45. It summarizes some of the hardware considerations discussed in the previous paragraphs.

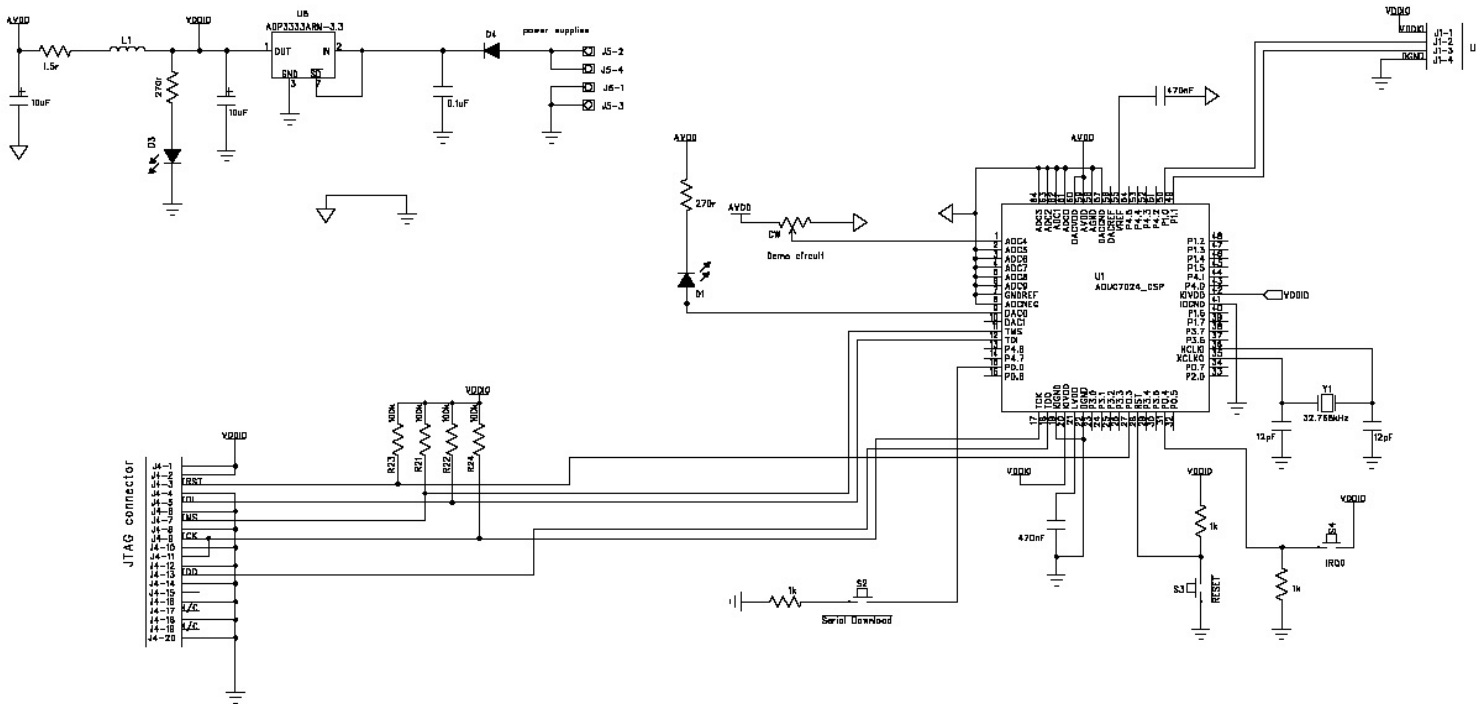

Figure 45: Typical System Configuration

DEVELOPMENT TOOLS

An entry level, low cost development system is available for the ADuC702X family. This system consists of the following PC-based (Windows® compatible) hardware and software development tools:

Hardware:

- ADuC702x Evaluation board
- Serial Port programming cable
- JTAG emulator

Software:

- Integrated Development Environment, incorporating assembler, compiler and non intrusive JTAG-based debugger
- Serial Downloader software
- Example Code

Miscellaneous:

- CD-ROM Documentation

IN-CIRCUIT SERIAL DOWNLOADER

The Serial Downloader is a Windows application that allows the user to serially download an assembled program to the on-chip program FLASH/EE memory via the serial port on a standard PC.

OUTLINE DIMENSIONS

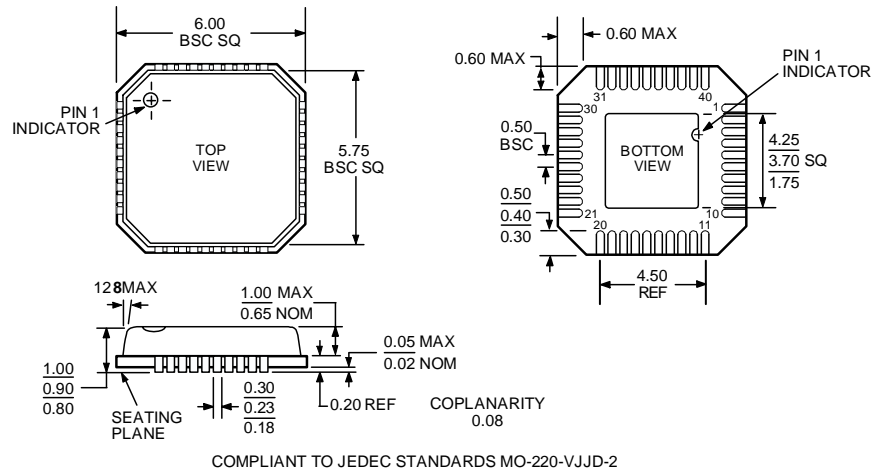

Figure 6. 40-Lead Frame Chip Scale Package [LFCSP] (CP-40)—Dimensions shown in millimetres

64-Lead Lead Frame Chip Scale Package [LFCSP]
9 x 9 mm Body
(CP-64-1)
Dimensions shown in millimetres

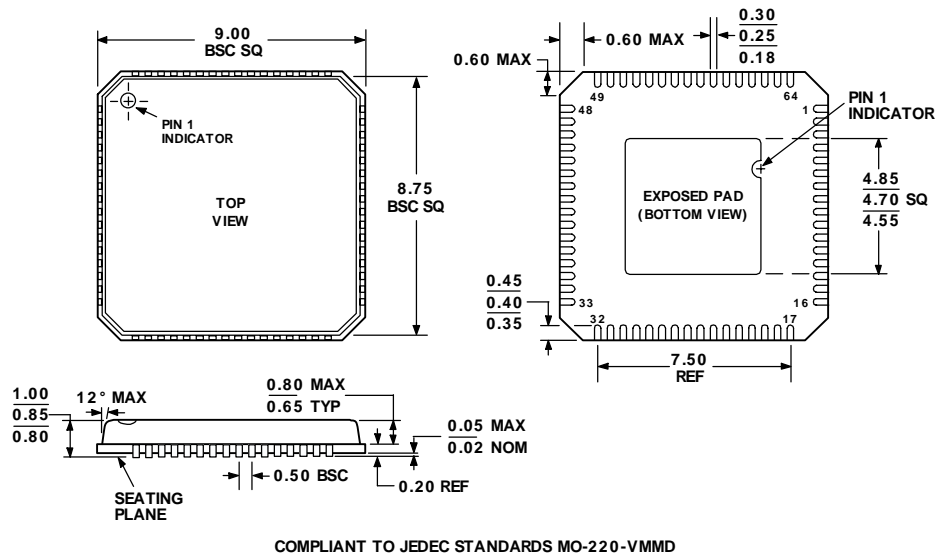

Figure 46. 64-Lead Frame Chip Scale Package [LFCSP] (CP-64-1)—Dimensions shown in millimetres

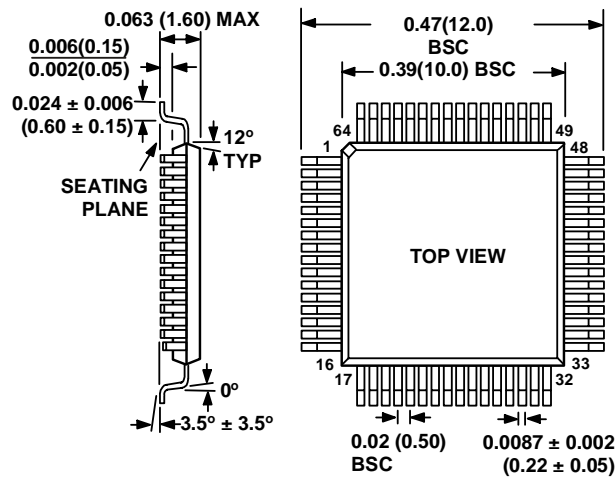

Figure 47. 64-Lead LQF Package [LQFP] (S-64)—Dimensions shown in millimetres

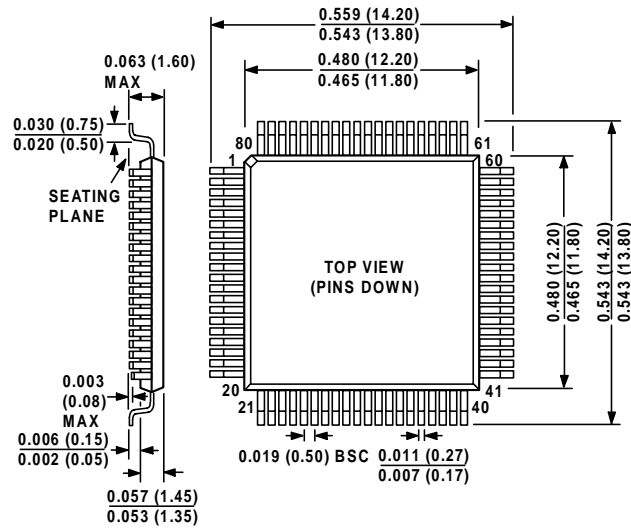

Figure 2. 80-Lead LQF Package [LQFP] (S-80)—Dimensions shown in millimetres